

INSTRUCTION MANUAL

HEAVY DUTY

AIR COMPRESSORS - OWNER'S MANUAL

INDEX

1. SYMBOLS	03
2. INTRODUCTION	04
3. EQUIPMENT INSPECTION	04
4. APPLICATION	05
5. SAFETY INSTRUCTIONS	05
6. INSTALLATION	07
7. STARTUP CHECKLIST	15
8. BREAK-IN PROCEDURES	15
9. MAINTENANCE SCHEDULE	16
10. TROUBLESHOOTING	20
11. LIMITED WARRANTY	21
12. WARRANTY GENERAL CONDITIONS	22
13. TECHNICAL DATA 580VL20X	24
14. TECHNICAL DATA 580VV20X	26
15. TECHNICAL DATA 580HV20X	28
16. TECHNICAL DATA 7.580VL30X	30
17. TECHNICAL DATA 580VL30X	32
18. TECHNICAL DATA 7.580VV30X	34
19. TECHNICAL DATA 7.580HV30X	36
20. TECHNICAL DATA 10120HL40X	38
21. TECHNICAL DATA 10120HW40X	41
22. TECHNICAL DATA 10120VW40X	44
23. TECHNICAL DATA 15120HW60X	45
24. TECHNICAL DATA 15120VW60X	48
25. TECHNICAL DATA 20120HVV80X 51	49
26. TECHNICAL DATA MCSV-20 HEAVY DUTY	52
27. TECHNICAL DATA MCSV-20 AUDAZ	59
28. ENVIRONMENTAL GUIDANCE AND RECOMMENDATIONS	64
29. SCHULZ AUTHORIZED DEALER	64

1. SYMBOLS | SIMBOLOGÍAS

The following symbols that are in the product and in the manual, meant to remind you about the safety precautions that must be respected.

Los siguientes símbolos presentado en el producto y manual, tienen el objetivo de recordarle sobre las precauciones de seguridad que deben ser respetadas.



READ MANUAL
LEA EL MANUAL



WEAR EAR PROTECTORS
UTILICE PROTECCIÓN AUDICULAR



EYE PROTECTION MUST BE WORN
UTILICE PROTECCIÓN PARA LOS OJOS



RESPIRATORY PROTECTION
UTILICE PROTECCIÓN RESPIRATORIA



EAR, EYE AND HEAD PROTECTION MUST BE WORN
DEBE SER UTILIZADA PROTECCIÓN PARA LOS OJOS, OÍDOS Y CABEZA



SAFETY GLOVES MUST BE WORN
DEBEN SER UTILIZADOS GUANTES DE SEGURIDAD



PROTECTIVE FOOTWEAR MUST BE WORN
DEBEN SER UTILIZADOS CALZADOS PROTECTORES



WARNING
AVISO



WARNING ELECTRICITY
RIESGO ELÉCTRICO



WARNING AUTOMATIC START UP
PELIGRO ENCENDIDO AUTOMÁTICO



ROTATING PARTS
PIEZAS EN MOVIMIENTO



TIPOVER HAZARD
RIESGO DE DESLIZAMIENTO



BUM HAZARD
RIESGO DE QUEMADURA



HIGH TEMPERATURE
ALTA TEMPERATURA



FLAMMABLE MATERIAL
MATERIAL INFLAMABLE



AIR WITH CONTAMINANTS
AIRE CON CONTAMINANTE



DRAINING THE TANK
DRENAJE DEL TANQUE

Congratulations for purchasing a SCHULZ quality product.

A company certified with **ISO 9001** quality system and **ISO 14001** environmental management system.

Standards observed for the design and construction of the product: EN 1012-1, ABNT NBR NM 60335-1, ABNT NBR 10143, ABNT NBR 10144, ABNT NBR ISO 16528-1, ABNT NBR ISO 1217, NBR 60204, NR12 (Aspects related with design and manufacture of the product, installation actions, training and others also necessary to comply with NR12, are customer responsibility), NR13, Inmetro Regulation Standard for the construction of serial pressure vessels, NBR 14153, NBR 12100, NBR 16035-3, ASME VIII-1.



IMPORTANT

When using this product, basic safety precautions described in the SAFETY INSTRUCTIONS must be observed to reduce the risks and prevent personal or material damage to your equipment.

2. INTRODUCTION



FOR THE CORRECT USE OF THE SCHULZ PRODUCT, WE RECOMMEND THOROUGH READING AND COMPREHENSION OF THIS MANUAL.

- This Instruction Manual contains important information on use, installation, maintenance and safety, and should always be available for the operator.
- If there is any problem that cannot be solved by the information provided in this manual, please contact the nearest Schulz Authorized Dealer.
- To validate the warranty, the conditions presented in the TERM OF WARRANTY chapter must be observed.
- For the products with a tank, the final user is responsible for the installation, inspection, maintenance, operation and specific documentation of the Pressure Vessel, which should be carried out according to the existing legislation of each country (for example NR13). The pressure vessel's record must be kept in a safe place to be used when necessary.

3. EQUIPMENT INSPECTION

- Inspect and check if damages were caused by transport. If so, immediately contact the transportation company.
- Certify that all damaged parts are replaced and that all mechanical and electrical problems are solved before operating the equipment.
- Don't turn on the equipment if it is not in perfect working conditions.
- The compressor serial number is located on the label attached to the product. Write this serial number in the space provided for it at the end of the manual.

4. APPLICATION

SCHULZ air compressors were developed to supply compressed atmospheric air with pressure and flow according to the TECHNICAL FEATURES table or on the product identification sticker. Do not use it for other purposes or with settings different from specified characteristics.



ATTENTION

A properly set up compressor should have approximately 6 (six) starts per hour, around 70% under load (7 minutes) and 30% off / in relief (3 minutes). For other operating conditions or special applications, such as OEMs (Original Equipment Manufacturer) contact the factory for proper set up.

5. SAFETY INSTRUCTIONS



1. This equipment, if improperly used, can cause physical and material damage. To avoid this, follow the instructions below:

- This equipment must not be used by people with physical, sensorial, or mental handicaps, or without knowledge of use and training.
- People without the proper experience or knowledge may use this equipment only if supervised and instructed by someone who is responsible for his or her safety.
- This equipment must not be used by children under any circumstances.
- Do not use your equipment when tired, under the influence of medication, alcohol or drugs. Lack of attention during operation may result in serious personal injury;
- May cause mechanical or electrical interference on nearby sensitive equipment;
- Must be installed and operated in places that are ventilated and protected against humidity and presence of water.

2. Choose the equipment model best suited for its intended use, don't exceed maximum capacity, if necessary, acquire a more suitable model for your application. This will increase efficiency and safety in your work;



3. Always use suitable personal protective equipment (PPE), according to each application, such as dust glasses and masks, closed non-skid safety shoes and ear protection. This reduces the risks against personal injury;





4. As any motorized equipment, this product emits noise during operation. The recommendation is to install and/or use it in an enclosed place or away from others in the neighborhood, in order to reduce the impacts caused by noise pollution;



5. While in use, the equipment has electrical components and hot moving parts;

6. To reduce the risk of electrical shock, the following is recommended:

- Install a residual current circuit breaker. Consult an electrician to select and install this safety device;
- Do not use the equipment barefoot, in wet or very humid places, or do not touch metal surfaces, such as pipes, motors, gutters, fences, windows, doors, metal gates, etc, since this increases the risk of electrical shock;
- Before cleaning or performing maintenance, disconnect the equipment from the electrical power supply;
- Do not make splices in the cord. If required, ask for a power cord replacement through the nearest Schulz Authorized Dealer (costs of power cable replacement are the sole responsibility of the customer).
- Power outlet must be compatible to the equipment's plug. To reduce the risk of shock, do not change the plug's characteristics and do not use adapters. If required, replace the outlet with a suitable plug model.
- Do not use your electric equipment in explosive atmospheres (gas, liquid or dust). The motor may generate sparks that may cause explosion;
- Make sure the power switch is in the "off" position before connecting the equipment to the power supply.

- Do not make holes on power cords, gas or water pipes. Contact with water or electric wires may cause electric shock. The equipment's electric motor generates sparks which when in contact with flammable gases may cause an explosion;
7. **The user of this product must keep the pressure vessel's record book, provided by the manufacturer, available, attached to the other safety documents required by the standards provided by the country's current legislation, for as long as the vessel is used, until it is disposed of. The final user must follow the standards required in the local legislation regarding installation, maintenance, and operation of the pressure vessel (compressed air tank). The pressure vessel's useful life depends on several factors that contribute to determine it. This aspect must be monitored and established by a certified professional, according to the local legislation. Note: The hydrostatic test carried out during the product manufacturing does not replace the initial inspection, which must be carried out at the location where the product is installed, duly monitored by a certified professional, according to the local legislation. Schulz Compressores Ltda., manufacturer of the product, declares that the local legislation and inspection rule upon the above provided information, and that all prudent, preventive, and wise safety procedures must prevail. Consult the tank quality certificate for more product information.**
 8. Do not alter the settings of the safety valve, pressure switch and solenoid valves, since they come preset from the factory. If some adjustment is necessary on the product, use the service of the nearest SCHULZ AUTHORIZED DEALER.
 9. Never surpass the maximum pressure indicated on the compressor's identification name plate/sticker.
 10. Never operate the safety valve with the compressor under operation or pressure. This may cause injury due to shooting particles and/or burns when the valve is installed on hot parts;
 11. Verify condition of the product's safety systems. In case of abnormalities, suspend the use and contact SCHULZ AUTHORIZED DEALER for repairs.
 12. Never perform repairs or welding services on the tank, because they can affect its resistance or mask more serious problems. If there is any leak, crack or corrosive wear, immediately suspend use of the equipment and find a SCHULZ AUTHORIZED DEALER.
 13. Release all pressure in the tank before performing any maintenance;
 14.  The compressed air might contain pollutants that will cause harm to the health of humans, animals, ambient or foods, among others. The compressed air must be treated with adequate filters, according to application and use requirements. Consult the factory or a SCHULZ AUTHORIZED DEALER for more information.
 15. Never direct a high pressure air jet directly at another person or at the skin.
 16. Do not allow the compressor to come in contact with any flammable substances.
 17. To avoid accidents, always fasten the part /accessory properly before starting work. If required, use clamps.
 18.  Never clean the compressor with solvents or any other flammable products, use neutral detergent.
 19. In the presence of any abnormality, immediately suspend its operation and contact the nearest SCHULZ AUTHORIZED DEALER
 20.  The compressor automatically resumes operation after power supply is interrupted and then reestablished. Make sure the equipment is not connected to the power supply before proceeding with any intervention, even during a short period of power interruption.
 21.  In order to reduce the probability of an accident due to contact with rotating parts:
 - Do not operate, under any circumstances, the product while the protectors of the rotating parts (belt, sheave, and ventilator) are not installed;
 - Do not use long clothing, chains or jewelry that may come into contact with the moving part of the product during use. If you have long hair, tie it back before using it;
 - Remove all adjustment tools before turning your equipment on. A key or tool stuck in rotating parts of the equipment may cause serious injuries.
 22. In order to reduce the risk of tipping:

- Before elevating the compressor make sure that the forklift forks, hook and/or elevation belts are well adjusted (if necessary use chocks) on the product, in good conditions and capable of supporting the compressor's weight;
 - For correct elevation, the belts must be fixed on the tank or on the compressor's base (AD versions).
-  Avoid fixing the belts on the coil compressor block and/or connections in order to avoid damages to it;
- The products with vertical tank must be affixed to the concrete base, check INSTALLATION chapter.
- 23.** Make sure that the product's maintenance and operation are performed by a properly trained and qualified professional.
- 24.** Besides the care recommendations presented here, consult the MAIN COMPONENTS chapter.

6. INSTALATION

Location:

The air compressor should be installed in a clean, dry, well lighted, and well ventilated area on a level floor. The flywheel side of the compressor should be towards the wall and the distance between the compressor and the wall should be a minimum of 30" to allow proper cooling air circulation, inspections, and maintenance.



WARNING

Under no circumstances should a compressor be placed in an area that may be exposed to a toxic, volatile or corrosive atmosphere nor should toxic, volatile or corrosive agents be stored near the compressor.

Mounting:

Your compressor must be installed according to all applicable State and Local Laws. Shims may be needed to level the legs. Care must be taken when tightening anchor bolts. Uneven torque can lead to excessive vibration that can weaken welds and cause explosions. Tighten three leveled legs equally and leave the fourth nut loose.

Air Intake:

Do not locate the compressor where it could ingest toxic, volatile or corrosive vapors or extremely dirty air. If a remote inlet filter is going to be installed you must increase one pipe size for every ten feet in length and use a flex hose between the pump and any solid pipe to minimize the potential of damage from vibration.

Piping:

The main distribution line should not be any smaller than the pipe size of the shut off valve of the compressor. It is recommended that the shop air system be connected to the air compressor shut off valve with a flexible coupler to reduce the risk of damage from vibration. All airlines should slope to an accessible drain or moisture trap for removal of condensation. Make sure that there are no leaks in the airlines as even small leaks can cause your compressor to run outside of the rated duty cycle. A typical installation is shown on page 11, note that the feeder lines come off of the top of the main distribution line so that moisture can't enter the feeder line.



WARNING

ASME coded pressure vessels must not be modified, welded, repaired, reworked or subjected to operating conditions outside the nameplate ratings. Such actions will negate code status, affect insurance status and may cause severe personal injury, death and property damage.



WARNING

High voltage may cause personal injury or death. Disconnect and lockout/tagout per O.S.H.A. Regulation 1910.147 all electrical power supplies before opening the electrical enclosure or servicing.

Wiring:

Before starting the installation procedure, check that the building's electrical service has an adequate capacity to handle the motor and the same electrical characteristics (voltage, cycle, and phase). Install the compressor as close to the main power supply as possible and follow all National Electric Safety Codes as well as those dictated by State and Local authorities. A qualified electrician must do the electrical installation. Every compressor model has a specific power requirement and the wire size used is critical to a proper installation. The two tables (shown below) are for reference only and should not supersede specific National, State or Local code requirements. The compressor can be manufactured without a power switch, according to the product version. **The pressure switch must not be directly connected to the motor but to a control circuit. See "Electrical Diagram" page 10 and 11 to correct installation, according to the product version.**

30 amp circuit		40 amp circuit		60 amp circuit	
0-30 ft.	10 ga	0-25 ft.	8 ga	0-10 ft.	8 ga
31-50 ft.	8 ga	26-50 ft.	6 ga	11-30 ft.	6 ga
51-70 ft.	6 ga	51-75 ft.	4 ga	31-50 ft.	4 ga
up to 71 ft.	call the factory	up to 76 ft.	call the factory	up to 51 ft.	call the factory

Orientative table for wiring

Grounding instructions:

This product must be grounded to reduce the risk of an electric shock. Connect the Grounding cable to the motor's terminal, or if there is no terminal to the motor's frame.

Motor power [hp]		Input supply voltage [V]	Max.fuse (g./gG)* [A]
single-phase	three-phase		
3	-	230	50
5	-	230	35
-	5	460	20
7.5	-	230	80
-	7.5	230	50
-	7.5	460	25
-	10	230	63
-	10	460	35
-	15	230	100
-	15	460	50
-	20	230	100
-	20	460	63

Orientative table for fuses

* type 2 coordination



WARNING

The incorrect installation of the grounding wire connector may result in an electric shock. If it is necessary to replace or repair both the cable and the connector, do not connect or join the grounding wire to the neutral wire or other. The green wire, with or without yellow stripes, is only to the grounding function. In case of doubts regarding the grounding information or whether the product is properly grounded, make sure you contact a qualified electrician to verify the connections.

ELECTRICAL DIAGRAM

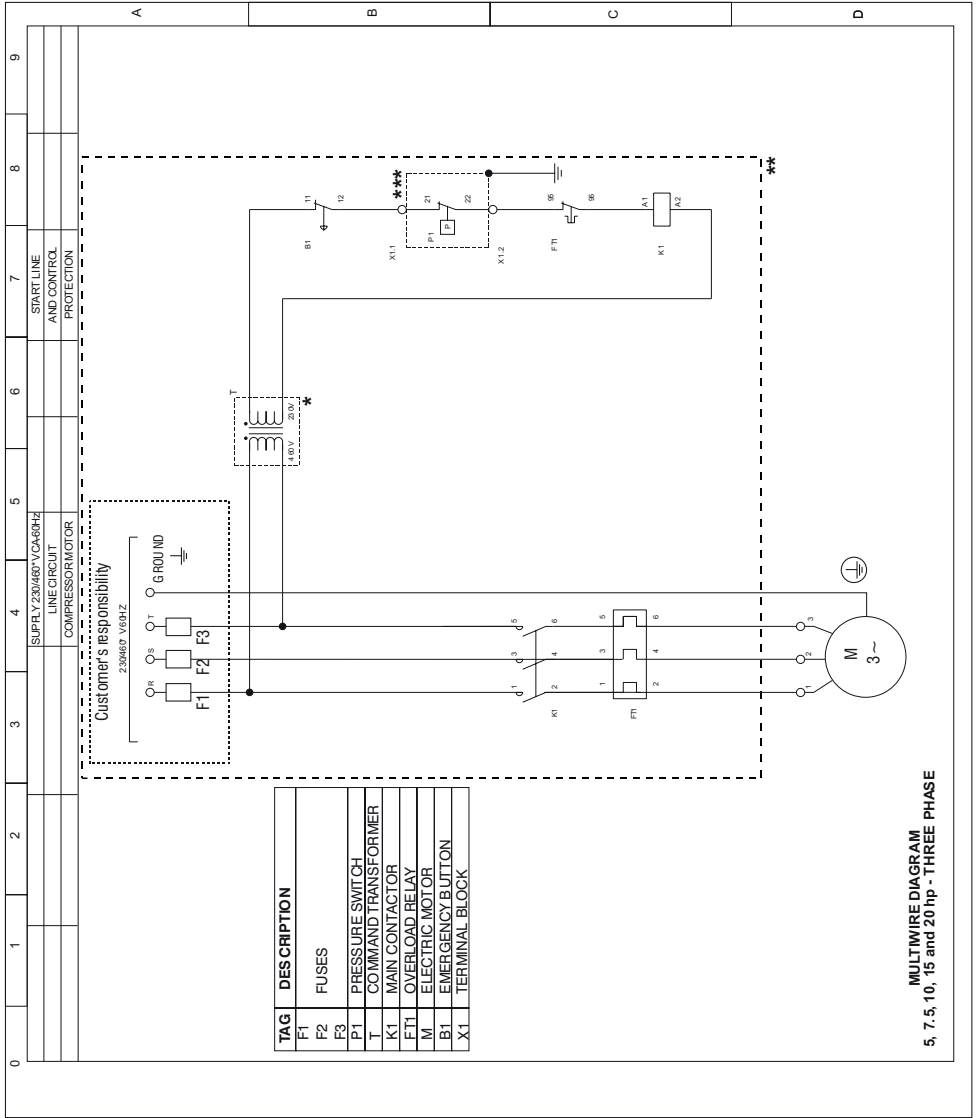

MULTIWIRE DIAGRAM
5, 7.5, 10, 15 and 20 hp - THREE PHASE

ELECTRICAL DIAGRAM

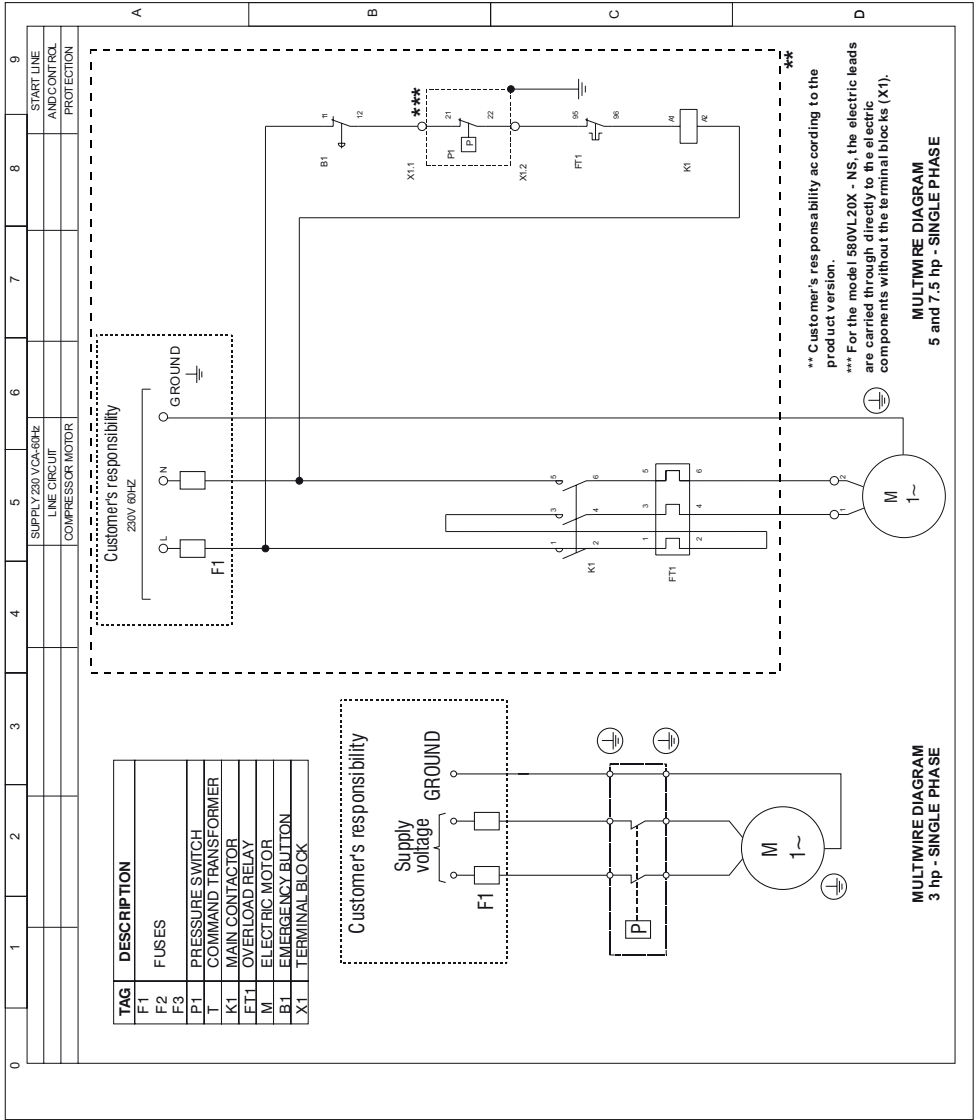

LAYOUT
DIRECT ON LINE STARTERS (D.O.L.)

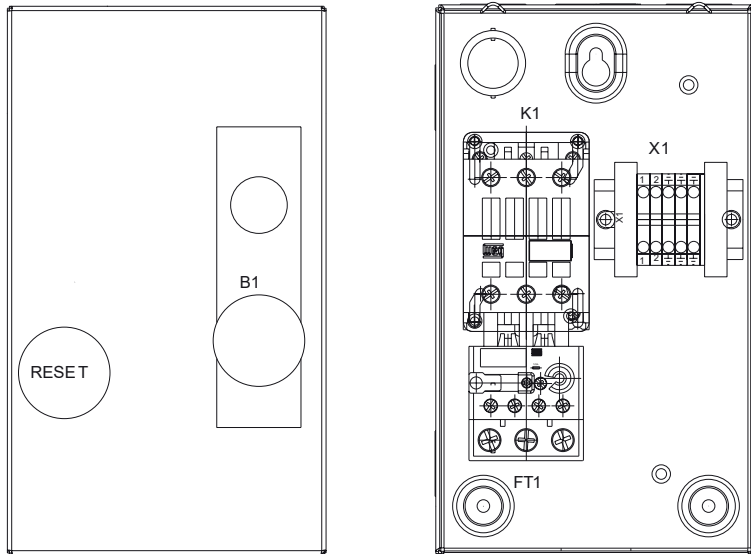

PARTS LAYOUT
 5, 7.5, 10, 15 and 20 hp

TAG	DESCRIPTION
K1	MAIN CONTACTOR
FT1	OVERLOAD RELAY
B1	EMERGENCY BUTTON
X1	TERMINAL BLOCKS

WIRING PROCEDURE

D.O.L. STARTER

SINGLE - PHASE

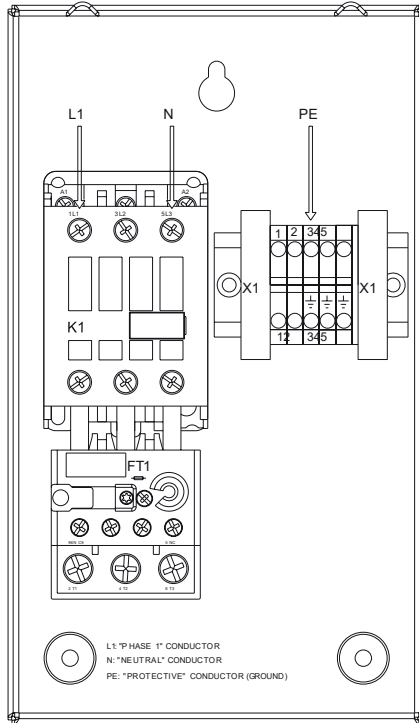

CUSTOMER WIRES LEADS:

MAKE LEADS "L1", "N" AND "PE" TO "1 L1", "5 L3" AND "X1.3" RESPECTIVELY, KEEPING THE OTHERS CONDUCTORS;

MANUFACTORY WIRES LEADS:

"96 NC" CONNECTED TO "A1"
 "5 L3" CONNECTED TO "A2"
 "1 L1" CONNECTED TO "RED BUTTON"
 "RED BUTTON" CONNECTED TO "X1.2"
 "X1.2" CONNECTED TO "PRESSURE SWITCH"
 "PRESSURE SWITCH" CONNECTED TO "X1.1"
 "X1.1" CONNECTED TO "95 NC"
 "2 T1" CONNECTED TO "3 L2"
 "X1.4" AND "X1.5" CONNECTED TO "PRESSURE SWITCH" AND "MOTOR"
 "4 T2" AND "6 T3" CONNECTED TO "MOTOR"



WARNING

Turn off the power and disconnect all supply source before servicing.

WIRING PROCEDURE

D.O.L. STARTER

THREE - PHASE

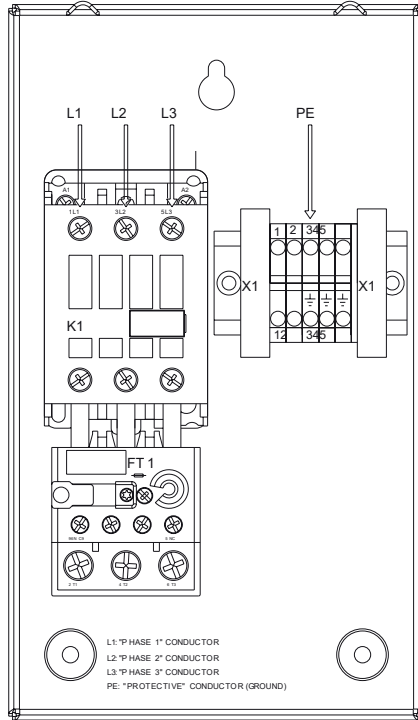

CUSTOMER WIRES LEADS:

MAKE LEADS "L1", "L2", "L3" AND "PE" TO "1 L1", "3 L2", "5 L3" AND "X1.3" RESPECTIVELY, KEEPING THE OTHERS CONDUCTORS;

MANUFACTORY WIRES LEADS:

"96 NC" CONNECTED TO "A1"
 "5 L3" CONNECTED TO "A2"
 "1 L1" CONNECTED TO "RED BUTTON"
 "RED BUTTON" CONNECTED TO "X1.2"
 "X1.2" CONNECTED TO "PRESSURE SWITCH"
 "PRESSURE SWITCH" CONNECTED TO "X1.1"
 "X1.1" CONNECTED TO "95 NC"
 "X1.4" AND "X1.5" CONNECTED TO "PRESSURE SWITCH" AND "MOTOR"
 "2 T1", "4 T2" AND "6 T3" CONNECTED TO "MOTOR"

WARNING:

- TURN OFF POWER BEFORE SERVICING
- COMPRESSOR FLYWHEEL ROTATION SHOULD BE COUNTERCLOCKWISE WHEN FACING FLYWHEEL
- IF COMPRESSOR FLYWHEEL ROTATION IS REVERSED (CLOCKWISE), QUICKLY TURN OFF THE POWER AND DISCONNECT ALL SUPPLY SOURCE AND INTERCHANGE THE "L1" AND "L2" WIRES.

NOTE:

The "wiring procedure" is only for reference also " Electrical Diagram" see page 10.

* For the product version in 460V:

The command wiring is carried out by a step-down transformer from 460V to 230V as showed on page 5 by "T".

AIR DISTRIBUTION NETWORK TYPICAL INSTALLATION DIAGRAM

This diagram is only a guide to a typical air system. Your needs may be different and you should consult a professional for more information regarding your particular installation.



WARNING

DANGER: Follow all safety precautions and warnings always turn off and lockout/tagout the main power supply before servicing unit.

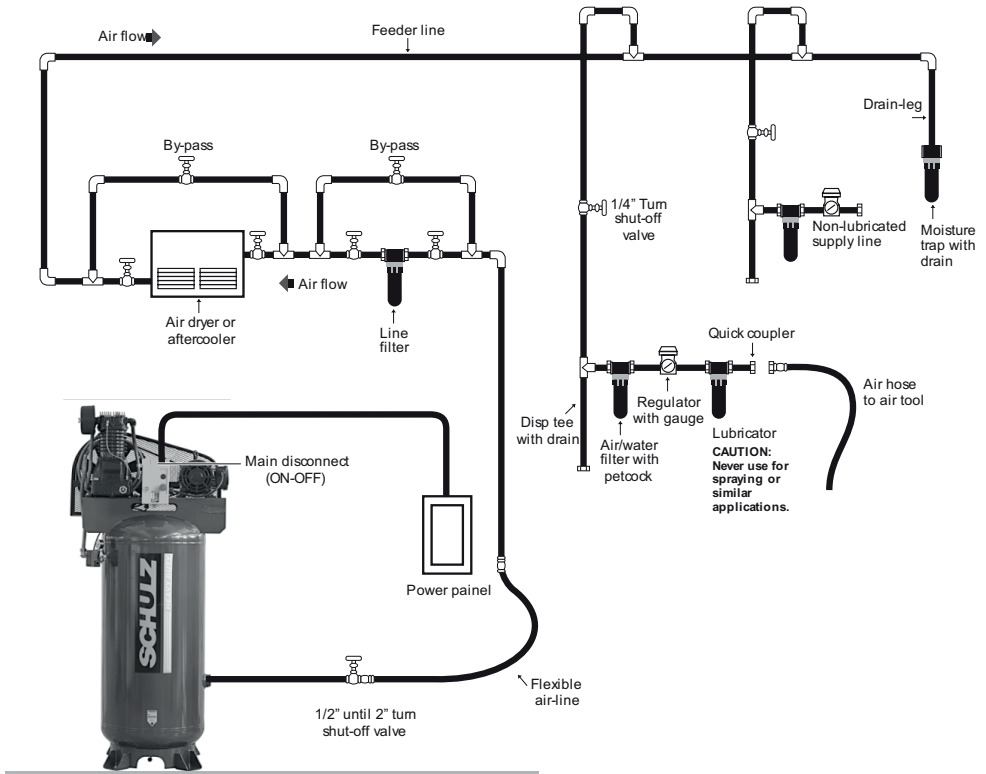

WARNING

To remove moisture from air line, the main feeder line must run downhill to drain-leg at a rate of 3/4" to 1" every 10'.



WARNING

Recommended pipe and fittings: black iron pipe no smaller than tank outlet size (NPT). For systems over 100 feet in length increase by one pipe size or loop air lines back to receiver.

7. STARTUP CHECKLIST



WARNING

Never assume a compressor is safe to work on just because it is not operating. It could restart at any time. Follow all safety precautions and guidelines outlined in this manual.

Go through this checklist **before** you start the compressor for the first time.



WARNING

Failure to perform the steps outlined in the start-up checklist, may result in mechanical failure, property damage, serious personal injury or even death.

1. Review Installation parameters in the prior section.

Double-check these items:

- Distance from walls at least 30".
- Properly mounted.
- Flexible coupler between compressor and shop.
- No toxic, volatile, or corrosive fumes in the area.
- Correct wire size, fuses, or circuit breakers.

2. Check the oil level in the pump and add if necessary.

3. Check that all pressure relief valves are in place and operational.

4. Check that the air filter is in place and securely mounted.

5. Remove all loose objects and tools around the compressor installation.

6. Open the service valve and any other shut off valves in the air system.

7. On three phase compressors, "bump" the motor to verify that you have the correct rotation (CCW facing the shaft). Reverse if necessary.

8. BREAK-IN PROCEDURES

After completing the START-UP CHECKLIST you are ready to run the compressor. Always go through this procedure before restarting your unit, if you have moved it to a new location or have had service on the pump or motor.

1. Start the compressor and check for excessive noise or vibration. If there is any condition that appears unsafe, stop the compressor immediately and fix the problem. If the compressor is running normally, allow the unit to pump for ten minutes before closing the service valve and allowing the compressor to pump up and shut off. Check the system for leaks.

2. Pay close attention to the compressor for the first hour of use. It is not necessary to run the compressor “un-loaded” to seat the rings.
3. During the first full day of running the compressor you should note how many times an hour the compressor is starting. During an “average” hour you should check what percent of those 60 minutes the compressor is running. If the compressor starts more than eight times or runs for more than 75 percent of an average hour, you need more air.
4. After eight hours of running, check the oil level and look for any oil leaks. Turn the compressor off and bleed down the tank pressure to about 20 psi and open the drain valve to allow all of the moisture to drain from the tank. Allow the pump to cool and torque the head bolts and the bolts which hold the inner and after cooler.
5. We recommend that you change your oil after the first 8 hours of operation. This could help remove any small particles in the pump and will improve the life of the pump.
6. After the first week of operation follow the guidelines in the MAINTENANCE SCHEDULE.

9. MAINTENANCE SCHEDULE

THE LIFE OF YOUR COMPRESSOR WILL BE DETERMINED BY HOW IT IS MAINTAINED.

- A clean pump will run cooler, causing less moisture in the tank and lines. Since the cooler the air is, the easier it is to compress, cleaning of the pump will make the motor and pump run less and save you money.
- A clean air filter will allow you to compress more air per cycle. A dirty air filter causes the oil from the crankcase to be sucked up past the piston rings if happens you get MAJOR problems. First, the oil gets into your air system, mixes with the water vapor in the lines and creates a “mayonnaise” that can foul up tools and destroy paint systems with “fish eye”. Secondly, the oil becomes baked onto the valve plates where it builds up and cuts the efficiency of the pump dramatically.
- Clean oil at the proper level in the crankcase is your best insurance against pump failure.
- A dry tank will last many more years than a tank with water sitting in it rusting away metal. The tank is a great heat sink and will take out the bulk the moisture that is in your air system if you drain it.

WARNING

Turn off power before servicing and be sure the air tank is unloaded. These instructions are based on normal operating conditions. If the compressor is located in an exceedingly dusty area, increase the frequency of all inspections.

DAILY

- Inspect the compressor visually.
- Check oil level and add some if necessary, before turning the compressor on.
- Drain moisture from the piping system.
- Be sure there is no excessive or unusual vibration or noise.

WEEKLY

- Remove and clean intake air filters; do not wash the filter element.
- Check V-belt for tightness. Belt tension should be adjusted to allow approximately 3/8" to 1/2" (9 to 13 mm) deflection with normal thumb pressure, see Figure page 16.
- Clean cylinders externally, cylinder head, motor, fan blade, tubing, and tank.
- ASME safety valve should be tested manually to see if it is working properly.

MONTHLY

- Check entire system for air leakage around fittings, etc by using water and soap lather.
- Check the pressure switch operation.
- Check for oil contamination and change it if necessary.

QUARTERLY

- Change the air filter element every 300 working hours or quarterly. (Whichever occurs first).
- Fasten bolts and nuts as required.
- Change oil more frequently if compressor is located in a very dirty environment.
- **WHILE RUNNING IN A PERIOD OF ABOUT 100 WORKING HOURS THE OIL LEVEL SHOULD BE CAREFULLY CHECKED.**

ANNUALLY

- Test and calibrate the pressure switch, pressure gauge and ASME safety valve according to their own technical standards. These parts must be removed from the tank and pump to be tested.
- Inspect and clean the suction and discharge valve(s) plate(s) every 1000 (one thousand) working hours (whichever occurs first), located between the cylinder and its cover and, if necessary, replace it (them) according to the operation conditions.

LUBRICATION

- The first oil change should be made after 8 hours of operation.
- The second oil change after 40 hours of operation.
- The third and following oil changes should be made after 200 hours of operation, or 60 (sixty) days, whichever occurs first.

NOTE:

Heavy Duty and multi-viscous oils are not adequate for Schulz air compressor's lubrication. The same applies to oils that tend to emulsify.

We recommend good industrial oil for air compressors, with rust and oxidation inhibitors and high viscosity level (from 90 to 95), SAE or ISO, as indicated in the table below:

SERVICE PROCEDURES



WARNING

Never assume a compressor is safe to work on just because it is not operating. It could restart at any time. Follow all safety precautions and guidelines outlined in this manual.

CRANKCASE OIL - The oil level should be half way to three quarters up the sight gauge when the compressor is stopped.

Do not over fill or check the oil level while the pump is running. Compressor must be level.

Use non-detergent, petroleum based, compressor or automotive grade oil only. Detergent or synthetic oil can damage the pump, cause excessive leaks, and will void the warranty. **DO NOT USE SYNTHETIC OIL IN THIS PUMP !**

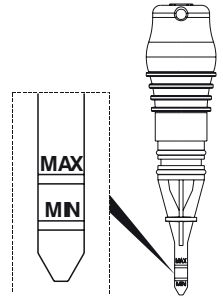

- RECOMMENDED LUBRICANT OILS FOR SCHULZ AIR PUMPS

AMBIENT TEMPERATURE OF (OC)		AMBIENT TEMPERATURE °F (°C)	
Below 32 °F Below 0 °C	32 ° F to 68 °F 0 °C to 20 °C	68 °F to 104 °F 20 °C to 40°C	
SAE 10W or ISO 32	SAE 20W or ISO 68	SAE 30 or ISO 100	



Change the oil when the compressor is warm so that the oil will drain out of the crankcase easier. Carefully open the plug on the crankcase drain, open the ball valve and drain the oil into a suitable container. Remove the crankcase fill plug to make the oil flow out faster. Allow the crankcase to drain completely. Replace the plug, and fill the crankcase to the proper level. Check the level carefully after the first day of use. Please recycle the used oil.

WARNING

Never attempt to change or fill the oil while the compressor is running. Do not work on the pump while it is hot as some parts of the pump can cause severe burns to unprotected skin. Never use flammable solvents to clean the pump or the intake system.

AIR FILTER - To service the air filter, remove the wing nut and cover that hold the element on to the intake assembly. Inspect the element and clean or replace as needed. Paper filters can be tapped out and back flushed with low-pressure air several times before they must be replace. Fiber (Micronite) filters can be washed out with soapy water, rinsed, and reused until the element material starts to deteriorate. Never use solvents to clean the filter or inlet parts. Always keep extra filter elements on hand. **NEVER RUN THE COMPRESSOR WITHOUT A FILTER.** Clean all parts and re-assemble in reverse order.

DRAIN THE TANK - To drain the moisture from the tank you should first reduce the air pressure in the tank and air lines to a safe pressure, around 20 psi. Open the drain valve and drain the moisture into a suitable container for disposal. All piston pumps have some level of oil bypass the rings and get pumped into the tank. This oil is measured in parts per million (PPM) and mixes with the moisture in the tank to form a whitish "mayonnaise" like substance.

Check with local codes concerning the discharge of this fluid directly into the sewer system.

Compressors used in commercial applications should be drained at least once a day. If you only run your compressor occasionally, it should be drained after each time you use it. Shops that run multiple shifts a day should have automatic drains to help reduce the moisture build up in the tank. A 5 HP compressor can dump as much as a gallon of moisture a day into the tank.

VALVES - The compressor pump has a set of reed valves manufactured from the highest quality stainless steel. These valves and the valve plates that hold them in place need to be maintained in order for the pump to work at its normal capacity. Once the valves become caked with carbonized dirt and oil they lose their ability to open and close properly and the amount of air that the compressor can make is dramatically compromised. Before starting this maintenance procedure you should make sure that you have a set of the gaskets you need to replace when you open up the pump.

1. Remove the air inlet assembly, inter cooler, and after cooler from the cylinder head of the pump.
2. Remove the cylinder head bolts after loosening all of them evenly, from the center out.
3. Remove the cylinder head and valve plates from the cylinder. Separate the head from the valve plates taking care to note the position of the valve plates for re-assembly. Use caution when separating the parts as the gaskets may be stuck together. Inspect the condition of the cylinder and piston for damage.
4. Clean the valves and valve plates with a stiff bristle brush or other suitable device. Do not use a steel wire brush as severe damage may result to the valve seat or valve.
5. Use clean safety solvent to loosen carbon deposits. NEVER use gasoline, thinners or other flammable solutions to clean valves or related parts. Remove all broken or defective gasket material.
6. To re-assemble the valve plates, a small amount of light grease or petroleum jelly can be used on clean, dry surfaces to hold the reed valves in place while they are assembled. Reserve the order to complete this operation and follow the recommended torque settings for the head bolts. Use a crosshatch pattern when tightening the head bolts.
7. Turn the pump over by hand several revolutions to make sure there are no problems. Review the START-UP CHECKLIST and follow the recommended BREAK-IN PROCEDURES. Re-torque the head bolts and check for leaks after one hour of running.

BELT TENSION - Proper belt tension and pulley alignment must be maintained for maximum drive efficiency and belt life. The correct tension exists if a deflection of 1/2" occurs by placing 10 pounds of force midway between the motor pulley and the pump flywheel. See figure below. This deflection can be adjusted using the following procedure.

1. Remove belt guard.
2. Loosen the motor mounting bolts. Remove belts.
3. Shift the motor to the point where the correct tension exists.
4. Retighten motor mounting bolts. Replace belts.
5. Check the tension again.
6. Replace the belt guard.

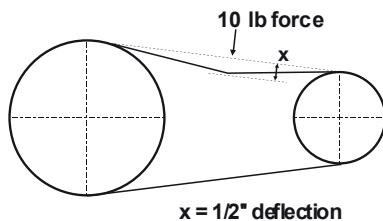

PULLEY ALIGNMENT - Three examples of pulley misalignment are shown below. To check the pulley alignment, remove the beltguard and place a straight edge against the pump flywheel. Measure the distance from the straight edge to the motor pulley at several points. If the pulley needs to be adjusted, follow the procedure below.

1. Loosen the motor mounting bolts.
2. Loosen the setscrews on the motor pulley.
3. Align the motor pulley using the straight edge as a guide.
4. Retighten the motor pulley setscrew using thread-locking fluid.
5. Adjust the belt tension as described previously.
6. Retighten the motor mounting bolts.
7. Replace the belt guard and test.

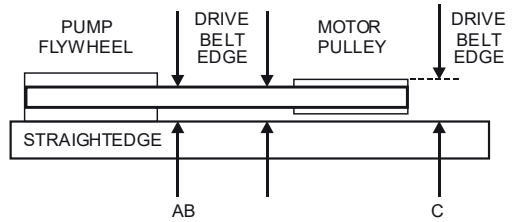
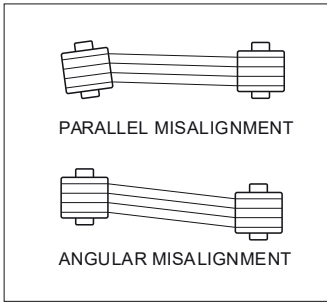

10. TROUBLESHOOTING

TROUBLE	POSSIBLE CAUSE	CORRECTIVE ACTION
Compressor will not start	No electrical power	Check or have system checked
	Tank pressure is between starting and stopping pressures	Wait until pressure drops
Motor overheats, blows fuses or overload relay cuts out	Wrong fuse size	Replace with correct size
	High ambient temperature	Provide ventilation. Check distance from the wall
	Wrong wire size	Have electrical system checked
	Thermal overload tripped	Allow to cool and reset overload relay
	One leg of supply line interrupted	Check all fuses and terminals for tightness. Check each leg
Pump using too much oil	Air filter dirty	Clean or replace element
	Oil level too high	Do not overfill crankcase
	Breather valve malfunctioning	Check valve and fix if broken
	Piston rings worn or broken	Check rings and replace if necessary
	Oil leaks	Tighten pump bolts or replace leaking gaskets
	Wrong oil viscosity, synthetic oil	Drain and refill with proper oil
Tank does not hold pressure	Diaphragm in pressure switch defective	Replace pressure switch
	Leaking fittings	Check for leaks and tighten
Compressor starts more than seven times per hour	High moisture level in tank Check valve leaks	Drain tank Drain air. Remove and fix
	Pressure switch set incorrectly	Check cut in and cut out setting
	Excessive air requirements	Decrease shop consumption by installing a regulator. Add another compressor to supply
	Leaks in air system	Inspect air system and fix
Compressor takes too long to fill tank	Excessive air requirement	Determine if compressor is properly sized for job
	Compressor not in optimal condition	Perform maintenance, check for loose belts, dirty air filter
	Dirty, sticking or damaged valves	Remove cylinder head and clean, replace damaged reed valves and gaskets
Compressor vibrates	Compressor not properly installed	Level the tank feet with vibration isolators and shims
	Mounting bolts too loose	Torque mounting bolts evenly
	Pulley and flywheel mis-aligned	Realign per manual
	Belts loose	Tighter per manual
Oil in discharge air	Compressor air intake restricted	Clean or replace filter element
	Excessive oil in the crankcase	Drain level to mid sight glass/dipstick, see Figure page 20
	Wrong oil viscosity	Drain pump and refill with the proper oil
	Worn rings	Replace rings
	Crankcase breather valve sticking	Clean or replace

TROUBLE	POSSIBLE CAUSE	CORRECTIVE ACTION
Water in the crankcase Oil appears milky	Compressor not running long enough to vaporize the water	Allow the compressor to run enough each day to vaporize the water
Compressor leaks down when off	Pressure switch diaphragm leaking	Replace pressure switch
	Check valve leaking	Drain tank, remove, clean and check valve. Replace if defective
	Fitting or valve leaking	Check for leaks and fix problem

11. LIMITED WARRANTY

Limited Warranty

The “Manufacturer” warrants this equipment to the original purchaser against manufacturing defects of the air compressor. The warranty covers one year for the electric motor and Pump and 90 days on all electrical components, such, contactor, pressure switches, fuses, and relays. except the Contractor Line of Products and all Gasoline Engine driven products. The warranty on contractor/engine driven models is 3 months, including the Legal Warranty – first 90 days (ninety days) from the date of the issue of the invoice, conditioned on the technical start (when applied) carried out by SCHULZ AUTHORIZED DEALER, subject to the purchase period of the invoice. Schulz will not cover rental equipment or time lost, oil or cleaning fees.

The warranty will be granted to the compressor unit provided that:

- A.** Periodicity is observed for the exchange of lubricating oil (Air end) and given installation conditions as instructed in this manual.
- B.** The lubricant oil used is oil for reciprocating air compressor recommended in this Manual, and the spare parts used are genuine SCHULZ parts.
- C.** The compressor will not operate without the filters or being damaged/clogged to the point of losing its filtering normal capacity.
- D.** The compressor is installed in a clean and free of dust and chemicals environment.

Where to repair product under Warranty

Only the Schulz Authorized Retail Store where the product was purchased can provide warranty services. Any service performed by a non authorized service person, voids the warranty. Engines must be taken to the proper factory authorized service center, I.e. Briggs & Stratton, Honda, Kohler, Robin.

What is covered under Warranty

Materials, parts and labor to repair the product are covered by this warranty. For products of 5HP and over, travel/mileage expenses are allowed. See limitations.

What is not covered by Warranty

Defects and damages from failure to perform factory suggested maintenance, wrong application, excessive wear and tear and rental use. Freight is not covered under warranty. Any loss of “shop time” is not covered by this warranty. Warranty is not to be considered a free maintenance program.

12. WARRANTY GENERAL CONDITIONS

- A.** The warranty period elapses from the purchase date of the product and not from the technical start (when applied).
- B.** Possible shutdown of the equipment, regardless of the reason, will not generate the right to compensation, repair, refund or return of any nature.
- C.** Warranty reception will only be held by SCHULZ AUTHORIZED DEALER in view of presentation of the original invoice, preferably on behalf of the customer.
- D.** It is not included in the warranty: parts that naturally wear out with regular use and that are influenced by installation and way of use of the product, such as: air filter, oil filter, valves, hoses, bearings, pressure gauges, fan of the frequency inverter, rotary shaft seal, oil level sight, ball valve, contactors, electronic sensors, electronic interface, air/oil separator element and lubricant oil.
- E.** Warranty will not include installation and cleaning services, bearing re lubrication, adjustments requested by the customer, change of lubricant oil and filters, damages to the external part of the product as well as damages that may result from improper use, neglect, modifications, external agents, bad weather, use of improper accessories, bad dimensioning for the applications it is intended to, falls, perforations, operation different from the directions of the Instruction Manual, power connections to improper voltages or to power lines subject to excessive variations, overloads or fuel use (portable compressors) of poor quality.
- F.** The warranty of the motor (electric and diesel) and of the component parts of the electric panel (electric switch) is subject to surety and issue of a technical report provided by their manufacturer which informs defects in material and workmanship.
- G.** The power voltage of the command must operate within the variation of $\pm 10\%$.

LIMITED WARRANTY

- A.** Any repairs or compensation for damage caused during transportation are not covered by the warranty.
- B.** The warranty will not include modifications in any component, unless directed by SCHULZ AUTHORIZED DEALER. SCHULZ OF AMERICA will not be liable for failures in the compressor, halts or damages due to not following all recommendations/ conditions listed in this manual.

WARRANTY EXTINCTION

This warranty will have no effect when:

- A.** As of the standard course of its expiration date, counted from the issue date of the invoice.
- B.** The technical start sheet is not sent to Schulz of America. (warranty@schulzamerica.com)
- C.** The product is sent for repair or moved (except portable) to another place by people/companies not authorized by SCHULZ OF AMERICA and presents signs of violation of its original characteristics or assembling out of the factory standards.
- D.** When air compressor is used for rental purposes.
- E.** The air compressor is exposed to any chemicals and dusty environment, exposed to the weather (installed outside without a roof covering that will protect the equipment from the weather)
- F.** When used with a generator and unsuitable electrical installation.
- G.** No maintenance has been performed on the air compressor, as stated in the user's manual.
- H.** The air compressor is not wired by the specifications on the user manual, meaning, the right wire gauge and disconnect fuses.

NOTES

- A.** The lubrication of the compressor is essential, which, to have a correct operation and long useful life, also needs oil change and elements of the preventive maintenance at regular intervals as indicated in this manual.

- B.** No SCHULZ retailer, representative or SCHULZ AUTHORIZED DEALER is authorized to change, add, delete, modify this Warranty, or take liabilities on behalf of Schulz S.A.
- C.** Compressors that may be without running (off, dead, with missing parts, etc.) during the period exceeding 6 (six) months should receive preventive maintenance before operating. The expenses from this maintenance are the customer's responsibility.

Note:

- 1.** Schulz of America reserves the right to make changes to this Instruction Manual without any previous notice.
- 2.** The product lines, Portable and Dryers do not require technical start.

Owner Responsibilities

It is the owner's responsibility to read and understand the operation manual for the unit and make certain his personnel are familiar with the correct operating procedures. After start-up, the customer is responsible for performing necessary routine maintenance procedures based on the operating conditions and in accordance with Schulz recommendations.

For example. Maintenance is the owner's responsibility.

- Keep oil level full
- Change oil as required
- Drain moisture from tank daily
- Keep unit clean
- Keep filters and valves clean and inspect them every 90 days
- Pull rings on all pressure relief valves every 3 months to assure popper operation
- Keep belts adjusted properly
- Keep all nuts and bolts tight on the unit
- Refer to your weekly, monthly, and yearly checklist in the manual

If you have any questions call your local distributor. They can go over or set up a maintenance plan with you. Under warranty claims, the owner may be asked to show proof of such during the investigation of any subsequent claim. The key to prompt and effective warranty administration and customer satisfaction is thorough investigation and reporting of operating conditions, maintenance records and all related issues. Problems should be discussed with the customer and all details and circumstances reviewed to determine if the product is within the warranty period. The product should then be inspected for cause of complaint to determine if the warranty may apply. Replacement parts transportation cost is not covered by the warranty statement. However, if a warrantable complaint occurs within 90 days from shipment, transportation will be allowed for both the replacement item and the returned suspect part if required. This allowance will cover only transportation via Schulz of America selected most economical method. Premium transportation such and/or handling charges will not be covered nor pro-rated.

Freight damages

Freight damage does not constitute warranty. It is the responsibility of the receiving customer to inspect the product for damages. The receiving party must file damages, shortages, or concealed damages with the delivering carrier on the receipt of delivery.

13. TECHNICAL DATA 580VL20X

MODEL	DISPLACEMENT		MAX. PRESSURE		TANK		RPM	Ø PULLEY		BELT SIZE	ELECTRIC MOTOR			DISCHARGE SIZE	OIL CAP.		WEIGHT WITH MOTOR		COLOR REF.
	cfm	l/min	psing	bar	Geom. Volume	gal		2P	inches		mm	hp	kW		VOLTAGE (V)	Volume	ml	in qt.	
580VL20X	20	566	175	12	300	80	985	4.5	115	1-A	5	3.75	Single-phase 230	1/2"	1,000	1,060	448	203	Black (pump) Gray (tank)

Compressor dimensions (inch/mm)

Height = 78/1,980, length = 31.5/800, width = 25.2 / 640

AIR COMPRESSOR PARTS

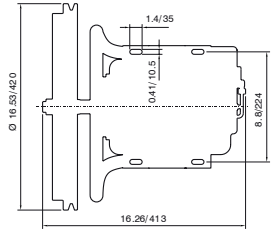
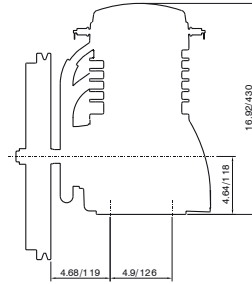

Note: dimensions in inch/mm.

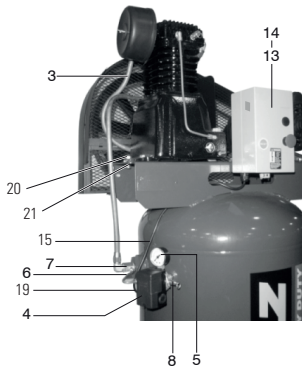

No.	CODE	DENOMINATION	QTY
1	932.7277-0	Bare pump	01
2	830.2355-0	Belt guard	01
3	709.1648-0	Aftercooler	01
4	012.1606-0/AT	Pressure switch	01
5	011.0114-0	Pressure gauge	01
6	709.0187-0	1/4" tube	01
7	60281012	Check valve	01
8	022.0277-0	1/4" ASME safety valve	01
9	25004056A	80 gal vertical tank	01
10	022.0232-0	1/4" tank drain valve	01
11	709.1248-0	Hose for tank drain (not shown)	01
12	21028503	Motor fastening plate	02
13	701.0378-0	Support start switch**	01
14	012.1559-0	Start switch**	01
15	012.1218-0	Start switch-pressure switch cord**	01
16	015.0587-0	Motor 230V	01
17	709.1659-0	Pulley	01
18	004.0127-0	Belt (not shown)	01
19	012.0322-0	Strain relief	01
20	*	3/8" x 1" hex head bolt	04
21	*	3/8" hex nut	04
22	*	3/8" x 7/8" hex head bolt (fix motor)	04

* Part available in the market - not sold by Schulz.

** Optional start switch

BARE PUMP PARTS

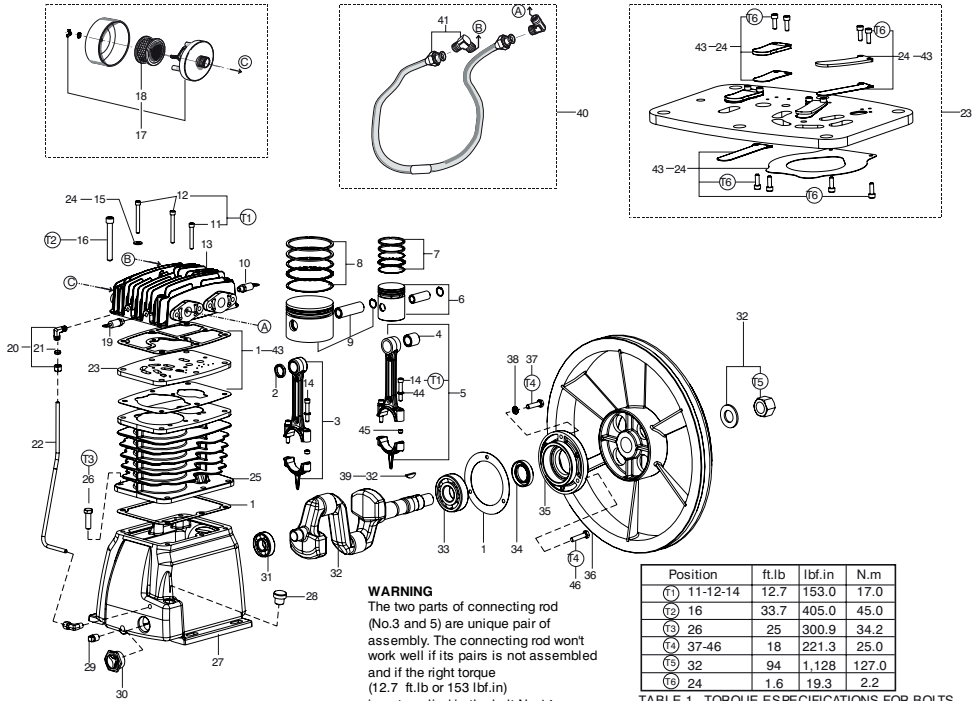

Position	ft.lb	lbf.in	N.m
(1) 11-12-14	12.7	153.0	17.0
(2) 16	33.7	405.0	45.0
(3) 26	25	300.9	34.2
(4) 37-46	18	221.3	25.0
(5) 32	94	1,128	127.0
(6) 24	1.6	19.3	2.2

TABLE 1 - TORQUE SPECIFICATIONS FOR BOLTS

No.	CODE	DENOMINATION	QTY
1	830.1088-0/NA	Gasket kit	01
2	013.0820-0	Spacer bushing	02
3	809.1074-0	LP connecting rod kit	01
4	019.0064-0	Needle bearing	01
5	830.1086-0	HP connecting rod with needle bearing kit	01
6	830.0786-0	HP Ø 2" piston	01
7	830.0823-0	HP 2" ring kit	01
8	830.0780-0	LP 90mm ring kit	01
9	016.0042-0	LP Ø 90mm piston	01
10	012.0177-0	HP 1/8" ASME safety valve	01
11	*	1/4" x 1.3/4" Allen hex. head bolt	01
12	*	1/4" x 2.1/4" Allen hex. head bolt	01
13	709.1401-0	Cylinder cover	01
14	*	1/4" x 1.1/2" Allen hex. head bolt	04
15	830.1032-0	Washer copper kit	01
16	*	3/8" x 3" Allen hex. head bolt	06
17	809.2416-0	3/4" NPT Air filter	01
18	007.0118-0	Filter element	01
19	022.0177-0	LP 1/8" ASME safety valve	01
20	003.0005-5	NPT 1/8" x 1/4" elbow	02
21	830.0599-8	1/4" ring kit	01
22	709.1417-0	Crankcase breather tube	01
23	809.1059-0	Valve plate	01

No.	CODE	DENOMINATION	QTY
24	830.1053-0	Valve plate kit	01
25	709.1569-0	Cylinder	01
26	*	3/8" x 1" hex. head bolt	06
27	709.1567-0	Crankcase	01
28	028.0297-0	M18 plug	01
29	003.0028-4	1/4" plug	01
30	003.0044-6	1" oil level sight	01
31	019.0002-1	6204 bearing	01
32	830.1087-0	Crankshaft kit	01
33	019.0007-2	6306 bearing	01
34	023.0338-0	Oil seal	01
35	709.1334-0	Flange	01
36	709.1062-0	Flywheel	01
37	*	5/16" x 1 hex. head bolt	02
38	*	5/16" lock washer	03
39	709.0163-3	Key	01
40	709.1581-0	Intercooler kit	01
41	003.0640-0	NPT 1/2" x 5/8" elbow	02
43	830.1055-0	Gasket/valve plate kit (kit)	01
44	*	1/4" Lock washer	04
45	809.1074-C	Guide bushing connecting rod	04
46	*	5/16" x 1.1/4" Hex. head bolt	01

Note: HP = high pressure LP = low pressure * Part available in the market - not sold by Schulz.

14. TECHNICAL DATA 580VV20X

MODEL	DISPLACEMENT		MAX. PRESSURE		TANK		rpm	Ø PULLEY		BELT SIZE	ELECTRIC MOTOR			DISCHARGE SIZE	OIL CAP.		WEIGHT WITH MOTOR		COLOR REF.
	cfm	l/min	psig	bar	Geom. Volume			2P	hp		kW	VOLTAGE (V)	ml		in qt.	lbs	Kg		
					l	gal												inches	
580VV20X	20	566	175	12	300	80	1050	8.5	216	1-A	5	3.75	Single-phase 230	1/2"	1,000	1,060	453	203	Black (pump) Gray (tank)
								4.8	124										

Compressor dimensions (inch/mm)

Height = 78/1,980, length = 31.5/800, width = 25.2 / 640

AIR COMPRESSOR PARTS

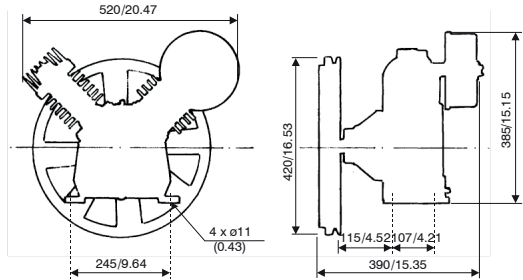
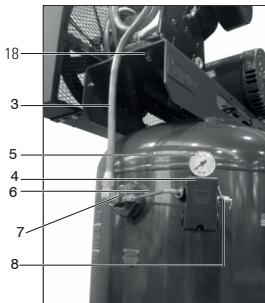

Note: dimensions in inch/mm.

No.	CODE single-phase	CODE three-phase	DENOMINATION	QTY
1	-	-	Bare pump	01
2	830.2262-0	-	Belt guard	01
3	709.1647-0	-	Aftercooler	01
4	012.1606-0/AT	-	Pressure switch	01
5	011.0114-0	-	Pressure gauge	01
6	709.0187-0	-	1/4" tube	01
7	60281012	-	Check valve	01
8	022.0277-0	-	1/4" ASME safety valve	01
9	25004056A	-	80 gal vertical tank	01
10	022.0232-0	-	1/4" tank drain valve	01
11	709.1248-0	-	Hose for tank drain (not shown)	01
12	21028503	-	Motor fastening plate	02
13	-	015.1041-0	Motor 208/230/460V 2P	01
14	015.0615-0	-	Motor 230V 4P	01
15	709.1168-0	20014041	Pulley 4P	01
16	004.0165-0	004.0127-0	Belt	01
17	*	*	3/8" x 1.1/4" hex head bolt (see note)	08
18	*	*	3/8" hex nut	04
19	*	*	3/8" x 7/8" hex head bolt	04

Note: For model with motor three-phase assembled 4 bolts.

* Part available in the market - not sold by Schulz.

BARE PUMP PARTS

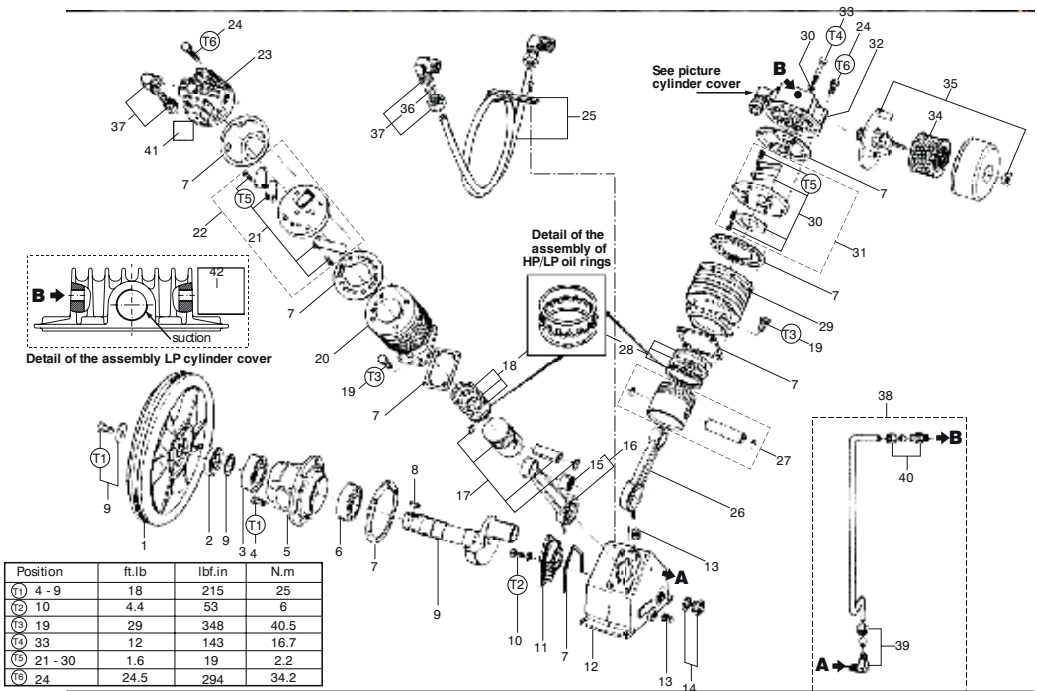

Position	ft.lb	lbf.in	N.m
(1) 4 - 9	18	215	25
(2) 10	4.4	53	6
(3) 19	29	348	40.5
(4) 33	12	143	16.7
(5) 21 - 30	1.6	19	2.2
(6) 24	24.5	294	34.2

TABLE 1 - TORQUE ESPECIFICACIONES FOR BOLTS

No.	CODE	DENOMINATION	QTY
1	709.1062-0	Flywheel (1-A)	01
2	023.0265-0	Oil seal	01
3	019.0004-8	6206 bearing	01
4	*	M8 x 1,25 x 20 hex. head screw	06
5	709.1056-0	Flange	01
6	019.0005-6	6207 bearing	01
7	830.0776-0/NA	Gasket kit	01
8	709.0163-3	Key	01
9	830.0778-0	Crankshaft	01
10	*	M5 x 0,8 x 20 head bolt	01
11	028.0756-0	Labyrinth cover	01
12	709.1231-0	Crankcase	01
13	003.0028-4	1/4" plug	02
14	830.0775-0	3/4" oil level sight	01
15	019.0064-0	Needle bearing	01
16	830.0783-0	HP connecting rod with needle bearing	01
17	830.0786-0	HP Ø 2" piston	01
18	830.0781-0	HP 2" ring kit	01
19	*	M10 x 1,5 x 25 hex. head bolt	08
20	709.1057-0	HP 2" cylinder	01
21	830.0782-0	HP valve plate kit	01

No.	CODE	DENOMINATION	QTY
22	830.0785-0	HP 2" valve plate	01
23	709.1332-0	HP 2" cylinder cover	01
24	*	M8 x 1,25 x 30 hex. head bolt	10
25	709.1075-0	Intercooler	01
26	709.1068-0	LP connecting rod	01
27	016.0042-0	LP Ø 90mm piston	01
28	830.0780-0	LP 90mm ring kit	01
29	709.1058-0	LP 90mm cylinder	01
30	830.0779-0	LP valve plate kit	01
31	830.0784-0	LP 90mm valve plate	01
32	709.1232-0	LP 90mm cylinder cover	01
33	*	M6 x 1,0 x 45 Allen hex. head bolt	01
34	809.2416-0	Air filter	01
35	007.0118-0	Filter element	01
36	830.0603-0	5/8" ring kit	01
37	003.0640-0	NPT 1/2" x 5/8" elbow	02
38	709.1230-0	Crankcase breather tube kit	01
39	003.0005-5	NPT 1/8"x1/4" elbow	01
40	003.0054-3	1/8"x1/4" straight connection	01
41	022.0215-0	HP 1/8" ASME safety valve	01
42	022.0177-0	LP 1/8" ASME safety valve	01

* Part available in the market - not sold by Schulz.

Note: HP = high pressure LP = low pressure

15. TECHNICAL DATA 580HV20X

MODEL	DISPLACEMENT		MAX. PRESSURE		TANK		rpm	Ø PULLEY		BELT SIZE	ELECTRIC MOTOR			DISCHARGE SIZE	OIL CAP.		WEIGHT WITH MOTOR		COLOR REF.
	cfm	l/min	psing	bar	Geom. Volume			2P	hp		kW	VOLTAGE (V)	ml		in qt.	lbs	kg		
580HV20X	20	566	175	12	300	80	1050	8.5		216			1-A	5	3.75	Single-phase	1/2"	1,000	1,060
					4.8	124		Three-phase	208/230/460										

Compressor dimensions (inch/mm)

Height = 42/1066.8 ; lenght = 56/1422.4 ; width = 23/584.2

AIR COMPRESSOR PARTS

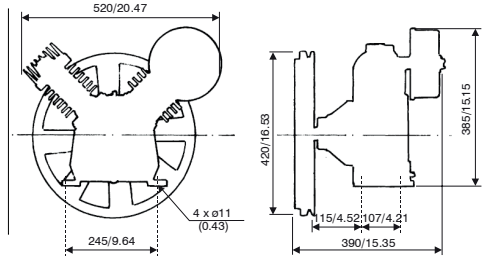
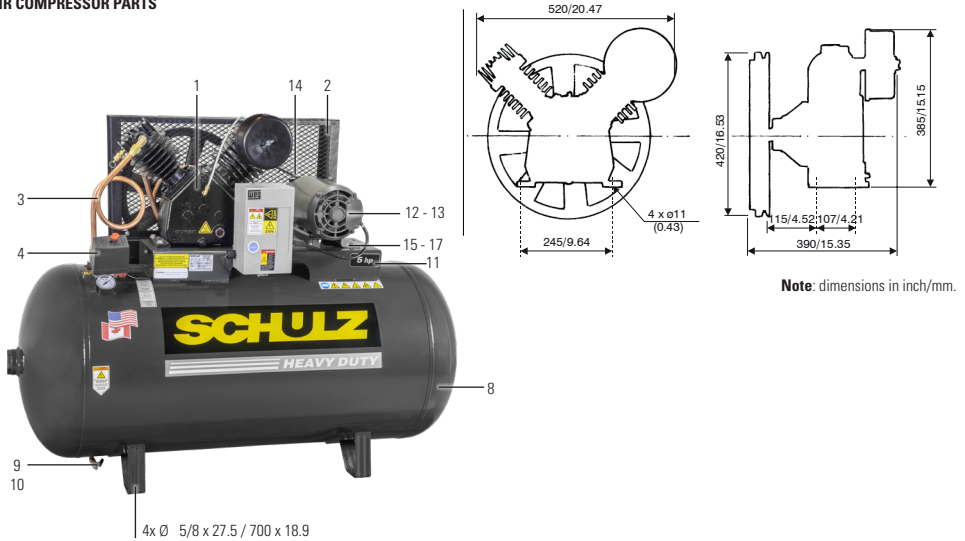

Note: dimensions in inch/mm.

4x Ø 5/8 x 27.5 / 700 x 18.9

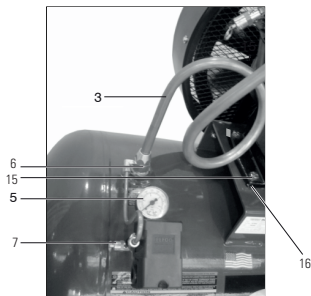

No.	CODE single-phase	CODE three-phase	DENOMINATION	QTY
1	-	-	Bare pump	01
2	830.2262-0	-	Belt guard	01
3	709.1116-0	-	Aftercooler	01
4	012.1606-0/AT	-	Pressure switch	01
5	011.0114-0	-	Pressure gauge	01
6	60281011	-	Check valve	01
7	022.0162-0	-	1/4" ASME safety valve	01
8	25003838A	-	80 gal vertical tank	01
9	022.0232-0	-	1/4" tank drain valve	01
10	709.1248-0	-	Hose for tank drain (not shown)	01
11	21028503	-	Motor fastening plate	02
12	015.0615-0	-	Motor 230V 4P	01
13	-	015.1041-0	Motor 208/230/460V 2P	01
14	004.0165-0	004.0127-0	Belt	01
15	*	-	3/8" x 1.1/4" hex head bolt (see note)	08
16	*	*	3/8" hex nut	04
17	-	*	3/8" x 1.1/2" hex head bolt	04
18	003.0270-0	-	1/4" nipple	04

Note: For model with motor three-phase assembled 4 bolts.

* Part available in the market - not sold by Schulz.

BARE PUMP PARTS

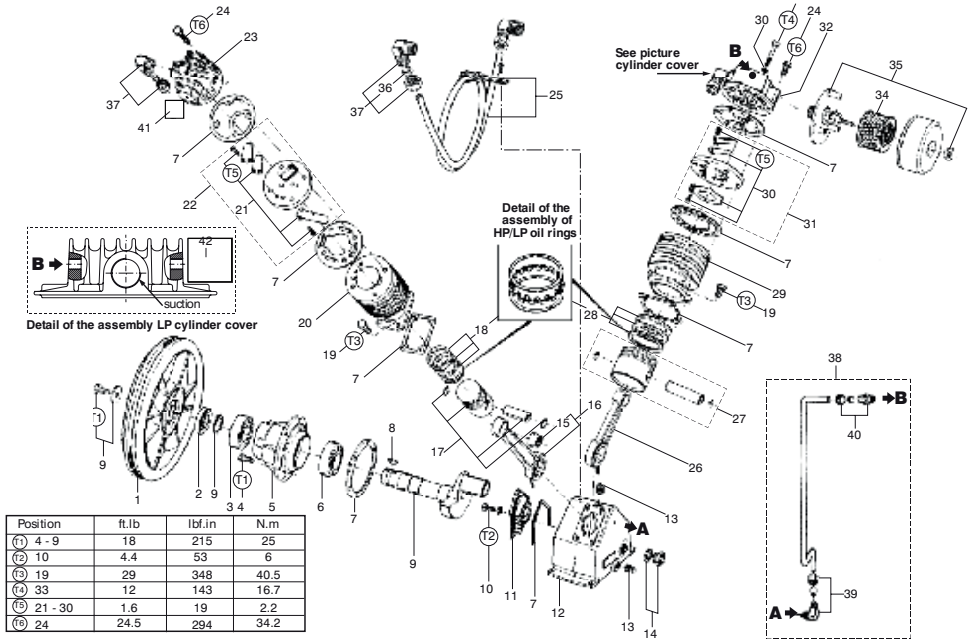

Position	ft.lb	lbf.in	N.m
(1) 4 - 9	18	215	25
(2) 10	4.4	53	6
(5) 19	29	348	40.5
(4) 33	12	143	16.7
(5) 21 - 30	1.6	19	2.2
(6) 24	24.5	294	34.2

TABLE 1 - TORQUE ESPECIFICATIONS FOR BOLTS

No.	CODE	DENOMINATION	QTY
1	709.1062-0	Flywheel (1-A)	01
2	023.0265-0	Oil seal	01
3	019.0004-8	6206 bearing	01
4	*	M8 x 1,25 x 20 hex. head screw	06
5	709.1056-0	Flange	01
6	30.354	6207 bearing	01
7	830.0776-0/NA	Gasket kit	01
8	709.0163-3	Key	01
9	830.0778-0	Crankshaft	01
10	*	M5 x 0,8 x 20 head bolt	01
11	200228001/AT	Labyrinth cover	01
12	709.1231-0	Crankcase	01
13	003.0028-4	1/4" plug	02
14	830.0775-0	3/4" oil level sight	01
15	019.0064-0	Needle bearing	01
16	830.0783-0	HP connecting rod with needle bearing	01
17	830.0786-0	HP Ø 2" piston	01
18	830.0781-0	HP 2" ring kit	01
19	*	M10 x 1,5 x 25 hex. head bolt	08
20	709.1057-0	HP 2" cylinder	01
21	830.0782-0	HP valve plate kit	01
22	830.0785-0	HP 2" valve plate	01

No.	CODE	DENOMINATION	QTY
23	709.1332-0	HP 2" cylinder cover	01
24	*	M8 x 1,25 x 30 hex. head bolt	10
25	709.1075-0	Intercooler	01
26	709.1068-0	LP connecting rod	01
27	016.0042-0	LP Ø 90mm piston	01
28	830.0780-0	LP 90mm ring kit	01
29	709.1058-0	LP 90mm cylinder	01
30	830.0779-0	LP valve plate kit	01
31	830.0784-0	LP 90mm valve plate	01
32	709.1232-0	LP 90mm cylinder cover	01
33	*	M6 x 1,0 x 45 Allen hex. head bolt	01
34	809.2416-0	Air filter	01
35	007.0118-0	Filter element	01
36	830.0603-0	5/8" ring kit	01
37	003.0640-0	NPT 1/2" x 5/8" elbow	02
38	709.1230-0	Crankcase breather tube kit	01
39	003.0005-5	NPT 1/8"x1/4" elbow	01
40	003.0054-3	1/8"x1/4" straight connection	01
41	022.0215-0	HP 1/8" ASME safety valve	01
42	022.0177-0	LP 1/8" ASME safety valve	01

* Part available in the market - not sold by Schulz.
 Note: HP = high pressure LP = low pressure

16. TECHNICAL DATA 7.580VL30X

MODEL	DISPLACEMENT		MAX. PRESSURE		TANK		RPM	Ø PULLEY		BELT SIZE	ELECTRIC MOTOR			DISCHARGE SIZE	OIL CAP.		WEIGHT WITH MOTOR		COLOR REF.
	cfm	l/min	psig	bar	Geom. Volume	gal		2P	inches		mm	hp	kW		VOLTAGE (V)	ml	in qt.	lbs	
7.580VL30X	30	850	175	12	300	80	820	4.0	100	2-A	7.5	5.6	Single-phase	1/2"	1,500	1,580	571	259	Black (pump) Gray (tank)
								4.1	103				230						

Compressor dimensions (inch/mm)

Height = 78.7/2,000, length = 33.8/860, width = 25.2 / 640

AIR COMPRESSOR PARTS

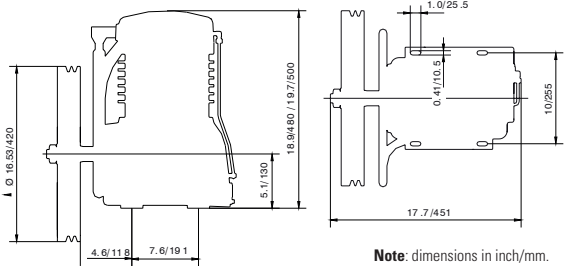
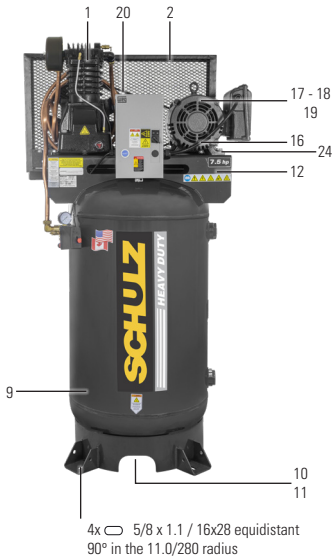

Note: dimensions in inch/mm.

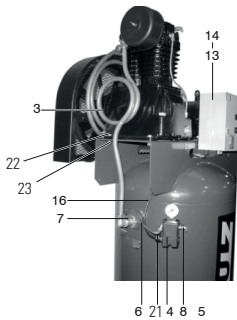

No.	CODE single-phase	CODE three-phase	DENOMINATION	QTY
1	**		Bare pump	01
2	830.2321-0		Belt guard	01
3	709.1658-0		Aftercooler	01
4	012.1606-0/AT		Pressure switch	01
5	011.0114-0		Pressure gauge	01
6	709.0187-0		1/4" tube	01
7	022.0277-0		Check valve	01
8	022.0162-0		1/4" ASME safety valve	01
9	25004055A		80 gal vertical tank	01
10	022.0232-0		1/4" tank drain valve	01
11	709.1248-0		Hose for tank drain (not shown)	01
12	21028503		Motor fastening plate	02
13	701.0377-0	701.0378-0	Support start switch	01
14	012.1595-0	012.1560-0	Start switch	01
15	012.1218-0		Start switch-pressure switch cord	01
16	012.0901-0	012.1080-0	Motor start switch cord	01
17	-	015.1042-0	Motor 208/230/460V	01
18	015.0584-0	-	Motor 230V	01
19	709.1660-0	709.1820-0	Pulley	01
20	004.0129-0		Belt	02
21	012.0723-0		Strain relief	01
22	*	*	3/8" x 1.1/4" hex head	04
23	*	*	3/8" hex nut	04
24	*	*	3/8" x 1.1/2" hex head	04

* Part available in the market -not sold by Schulz.

** Item upon request

BARE PUMP PARTS

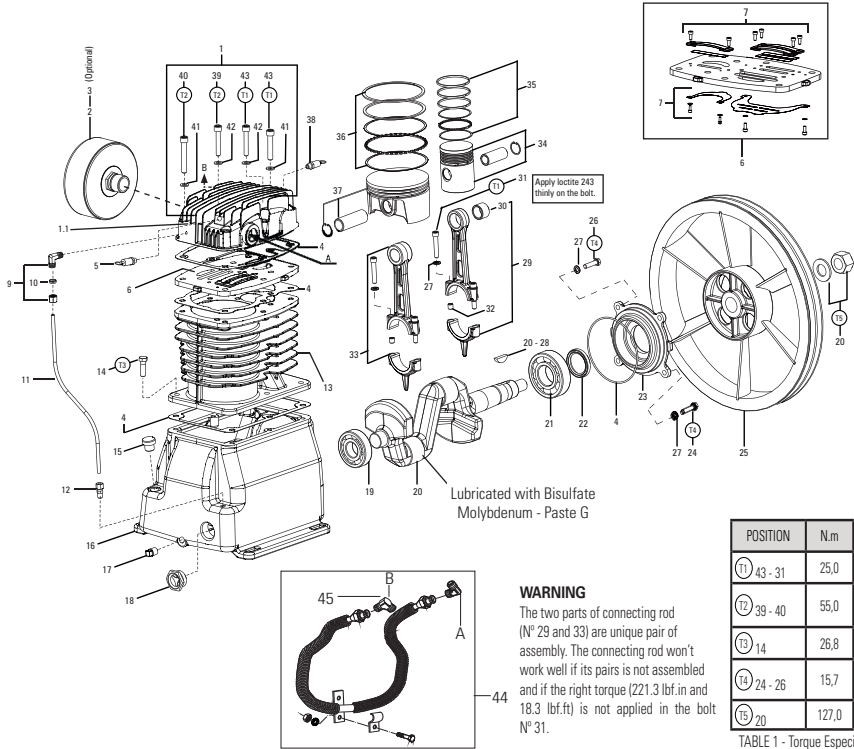

No.	CODE	DENOMINATION	QTY
1	830.1734-0/AT	Cylinder cover with kit	01
1.1	709.1338-0/AT	Cylinder cover	01
2	809.2417-0	1" NPT Air filter	01
3	830.1257-0	Filter element	01
4	830.1897-0	Gasket (kit)	01
5	022.0177-0/AT	LP 1/8" ASME safety valve	01
6	809.1787-0/AT	Valve plate	01
7	830.1898-0	Valve plate repair	01
9	003.0005-5/AT	NPT 1/8" x 1/4" elbow	01
10	830.0599-8	1/4" ring (kit)	01
11	709.1585-0/AT	Crankcase breather tube	01
12	003.0054-3/AT	NPT 1/8" x 1/4" straight connection	01
13	709.1708-0/AT	Cylinder D=120mm d=2.1/2"	01
14	*	3/8" x 1" Hex. head bolt	06
15	028.0297-0/AT	M18 plug	01
16	709.1574-0/AT	Crankcase with breather for cover	01
17	003.0028-4/AT	1/4" plug	01
18	830.0154-2	1" oil level sight	01
19	019.0007-2/AT	6306 bearing	01
20	830.1092-0	Crankshaft (kit)	01
21	019.0074-0/AT	6308 bearing	01
22	60082501/AT	Oil seal	01
23	709.1577-0/AT	Flange	01
24	*	5/16" x 1" Hex. head bolt **	01
25	709.1405-0/AT	Flywheel	01

No.	CODE	DENOMINATION	QTY
26	*	5/16" x 1.1/4" Hex. head bolt	03
27	*	5/16" lock washer	08
28	709.0147-1/AT	key	01
29	830.1093-0	HP connecting rod with bushing needle (kit)	01
30	019.0028-0/AT	Bushing needle	01
31	*	5/16" x 1.3/4" Allen hex. head bolt	04
32	809.1082-C/AT	Guide bushing connecting rod (kit with 4 pcs)	04
33	809.1083-0/AT	LP connecting rod (kit)	01
34	830.1079-0	HP Ø 2. 1/2" piston (kit)	01
35	830.1078-0	HP 2. 1/2" ring (kit)	01
36	830.1091-0	LP 120mm ring (kit)	01
37	016.0121-0/AT	LP Ø 120mm piston	01
38	022.0215-0/AT	HP 1/8" ASME safety valve	01
39	*	3/8" x 2.1/2" Allen hex. head bolt (see note 2)	04
40	*	3/8" x 1.1/2" allen hex head bolt	04
41	*	3/8" lock washer	06
42	830.1083-0	Washer copper (kit with 10 pcs)	02
43	*	5/16" x 1.3/4" Allen hex. head bolt	02
44	709.1592-0	Intercooler whit nut and elbow (kit)	01
45	003.0151-5	NPT 3/4" x 3/4" elbow	02

* Part available in the market - not sold by Schulz. ** Assembled of the intercooler holder (item 47).
Note: HP = high pressure LP = low pressure

17. TECHNICAL DATA 580VL30X

MODEL	DISPLACEMENT		MAX. PRESSURE		TANK		rpm	Ø PULLEY		BELT SIZE	ELECTRIC MOTOR			DISCHARGE SIZE	OIL CAP.		WEIGHT WITH MOTOR		COLOR REF.
	cfm	l/min	psing	bar	Geom. Volume	gal		2P	inches		mm	hp	kW		VOLTAGE (V)	ml	in. qt.	lbs	
580VL30X	30	850	175	12	300	80	534	4.0	100	4P	5	5.6	Single-phase 230	1/2"	1,500	1,580	502	228	Black (pump) Gray (tank)
								4.1	103				Three-phase 208/230/460						

Compressor dimensions (inch/mm)

Height = 78.7/2,000, length = 33.8/860, width = 25.2 / 640

AIR COMPRESSOR PARTS

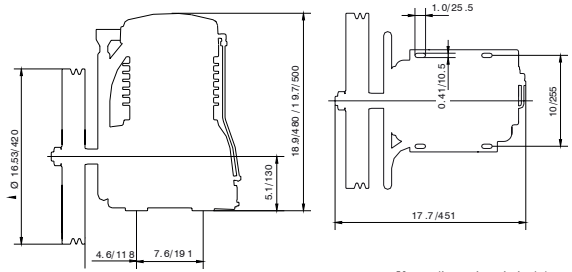
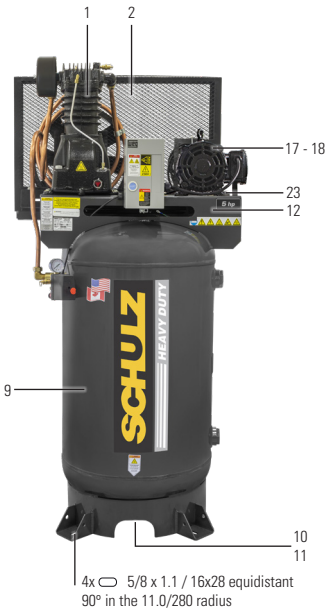

Note: dimensions in inch/mm.

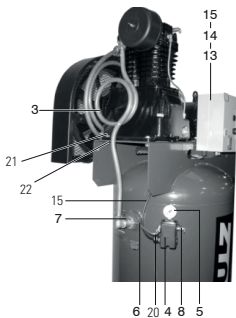

No.	CODE single-phase	CODE three-phase	DENOMINATION	QTY
1	932.9361-0	932.9362-0	Bare pump	01
2	830.2593-0		Belt guard	01
3	709.1658-0		Aftercooler	01
4	012.1606-0		Pressure switch	01
5	011.0114-0		Pressure gauge	01
6	709.0187-0		1/4" tube	01
7	022.0213-0		Check valve	01
8	022.0177-0		1/8" ASME safety valve	01
9	25004055A		80 gal vertical tank	01
10	809.1926-0		1/4" tank drain valve	01
11	709.1248-0		Hose for tank drain (not shown)	01
12	21028503		Motor fastening plate	02
13	701.0378-0		Support start switch	01
14	012.1559-0	012.1580-0	Start switch	01
15	012.1218-0		Start switch-pressure switch cord**	01
16	012.1196-0		Motor start switch cord**	01
17	015.0615-0	-	Motor 230V	01
18	709.2082-0	-	Pulley	01
19	004.0007-6		Belt	02
20	012.0723-0		Strain relief	01
21	*	*	3/8" x 2.1/2" Allen hex head bolt	04
22	*	*	3/8" hex nut	04
23	*	*	3/8" x 1.1/2" Allen hex head bolt	04

* Part available in the market - not sold by Schulz.

** Optional start switch

BARE PUMP PARTS

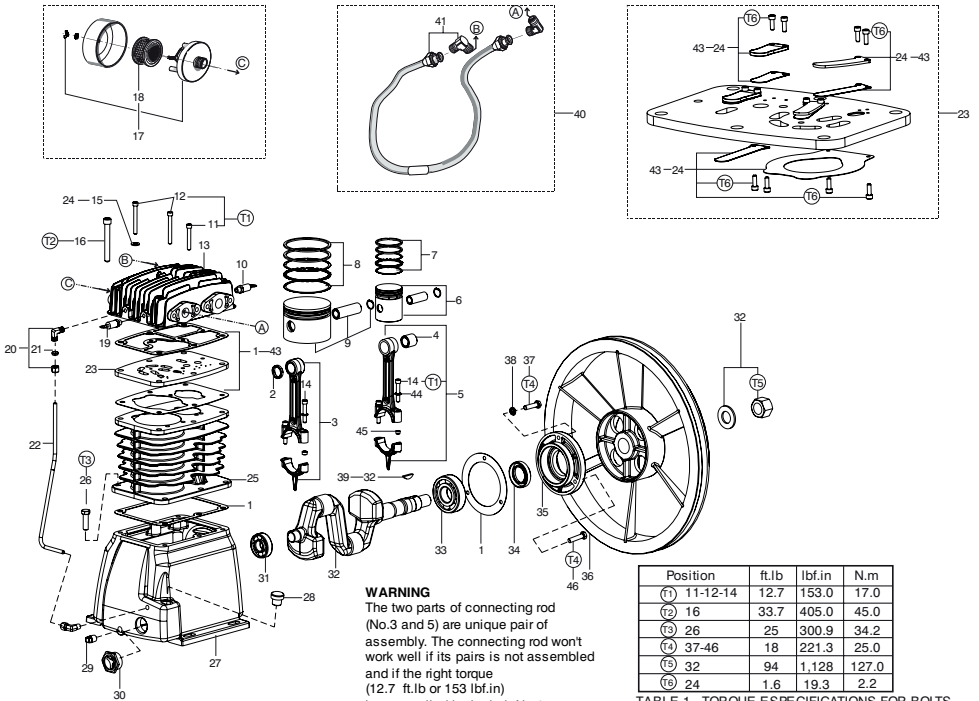

TABLE 1 - TORQUE ESPECIFICATIONS FOR BOLTS

No.	CODE	DENOMINATION	QTY
1	830.1090-0/NA	Gasket kit	01
2	013.0820-0	Spacer bushing	02
3	809.1083-0	LP connecting rod kit	01
4	019.0028-0	Needle bearing	01
5	809.1093-0	HP connecting rod with needle bearing kit	01
6	016.0121-0	HP 120mm piston	01
7	830.1091-0	HP 120mm ring kit	01
8	830.0983-0	LP 2.1/2" ring kit	01
9	830.1079-0	LP 2.1/2" piston	01
10	022.0177-0	HP 1/8" ASME safety valve	01
11	*	1/4" x 1.3/4" Allen hex. head bolt	01
12	*	1/4" x 2.1/4" Allen hex. head bolt	01
13	709.1338-0	Cylinder cover	01
14	*	1/4" x 1.1/2" Allen hex. head bolt	04
15	830.1083-0	Washer copper kit	01
16	*	3/8" x 3" Allen hex. head bolt	06
17	809.2417-0	1" NPT Air filter	01
18	007.0118-0	Filter element	01
19	022.0177-0	LP 1/8" ASME safety valve	01
20	003.0005-5	NPT 1/8" x 1/4" elbow	02
21	830.0599-8	1/4" ring kit	01
22	709.1585-0	Crankcase breather tube	01

No.	CODE	DENOMINATION	QTY
23	809.1787-0	Valve plate	01
24	830.1227-0/AT	Valve plate kit	01
25	709.1708-0	Cylinder	01
26	*	3/8" x 1" hex. head bolt	06
27	709.1574-0	Crankcase	01
28	028.0297-0	M18 plug	01
29	003.0028-4	1/4" plug	01
30	003.0044-6	1" oil level sight	01
31	019.0074-0	6204 bearing	01
32	830.1092-0	Crankshaft kit	01
33	019.0007-2	6306 bearing	01
34	60082501	Oil seal	01
35	709.1577-0	Flange	01
36	709.1405-0	Flywheel	01
37	*	5/16" x 1 hex. head bolt	02
38	*	5/16" lock washer	03
39	709.0147-1	Key	01
40	709.1592-0	Intercooler kit	01
41	003.0151-5	NPT 1/2" x 5/8" elbow	02
43	830.1898-0	Gasket/valve plate kit (kit)	01
44	*	1/4" Lock washer	04
45	830.1082-C	Guide bushing connecting rod	04
46	*	5/16" x 1. 1/4" Hex. head bolt **	01

Note: HP = high pressure LP = low pressure * Part available in the market - not sold by Schulz. ** Assembled of the intercooler holder (item 42).

18. TECHNICAL DATA 7.580VV30X

MODEL	DISPLACEMENT		MAX. PRESSURE		TANK		r/min	Ø PULLEY		BELT SIZE	ELECTRIC MOTOR			DISCHARGE SIZE	OIL CAP.		WEIGHT WITH MOTOR		COLOR REF.
	cfm	l/min	psing	bar	Geom. Volume	gal		2P	inches		mm	hp	kW		VOLTAGE (V)	ml	in. qt.	lbs	
7.580VV30X	30	850	175	12	300	80	960	9.0	226	2-A	7.5	5.6	Single-phase	1/2"	0,880	0,920	508	230	Black (pump) Gray (tank)
								4.5	115				Three-phase						

Compressor dimensions (inch/mm)

Height = 74.8/1,900, lenght = 39.3/1,000, width = 25.2 / 640

AIR COMPRESSOR PARTS

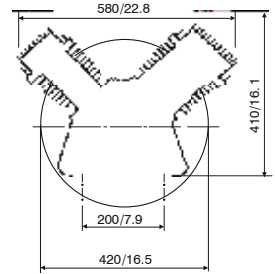
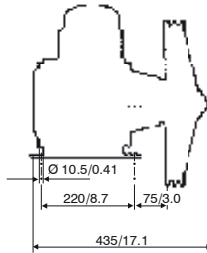
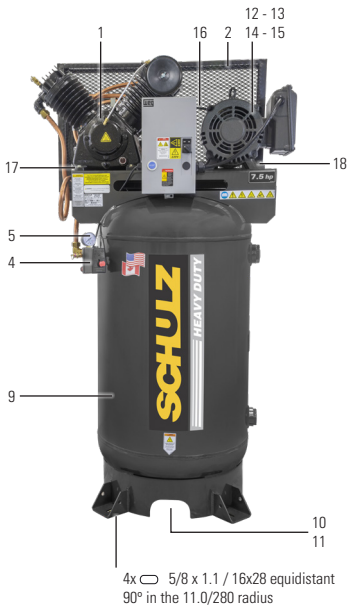

Note: dimensions in inch/mm.

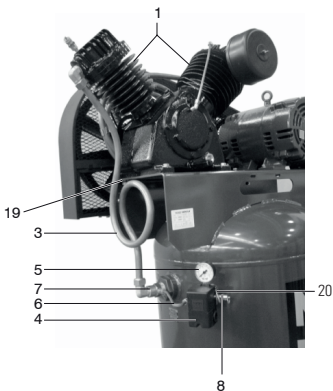

No.	CODE single-phase	CODE three-phase	DENOMINATION	QTY
1	-	-	Bare pump	01
2	830.2321-0	-	Belt guard	01
3	709.1657-0	-	Aftercooler	01
4	012.1606-0/AT	-	Pressure switch	01
5	011.0114-0	-	Pressure gauge	01
6	709.0187-0	-	1/4" tube	01
7	022.0213-0	-	Check valve	01
8	022.0277-0	-	1/4" ASME safety valve	01
9	25004055A	-	80 gal vertical tank	01
10	022.0232-0	-	1/4" tank drain valve	01
11	709.1248-0	-	Hose for tank drain (not shown)	01
12	-	015.1042-0	Motor 208/230/460V 2P	01
13	015.0616-0	-	Motor 230V 4P	01
14	709.0928-6	-	Pulley 4P	01
15	-	709.1661-0	Pulley 2P	01
16	004.0125-0	004.0110-0	Belt	02
17	*	*	3/8" x 1.1/4" hex head	04
18	*	*	3/8" x 1.1/2" hex head	04
19	*	*	3/8" hex nut	04
20	003.0270-0	-	1/4" nipple	01

* Part available in the market -not sold by Schulz.

BARE PUMP PARTS

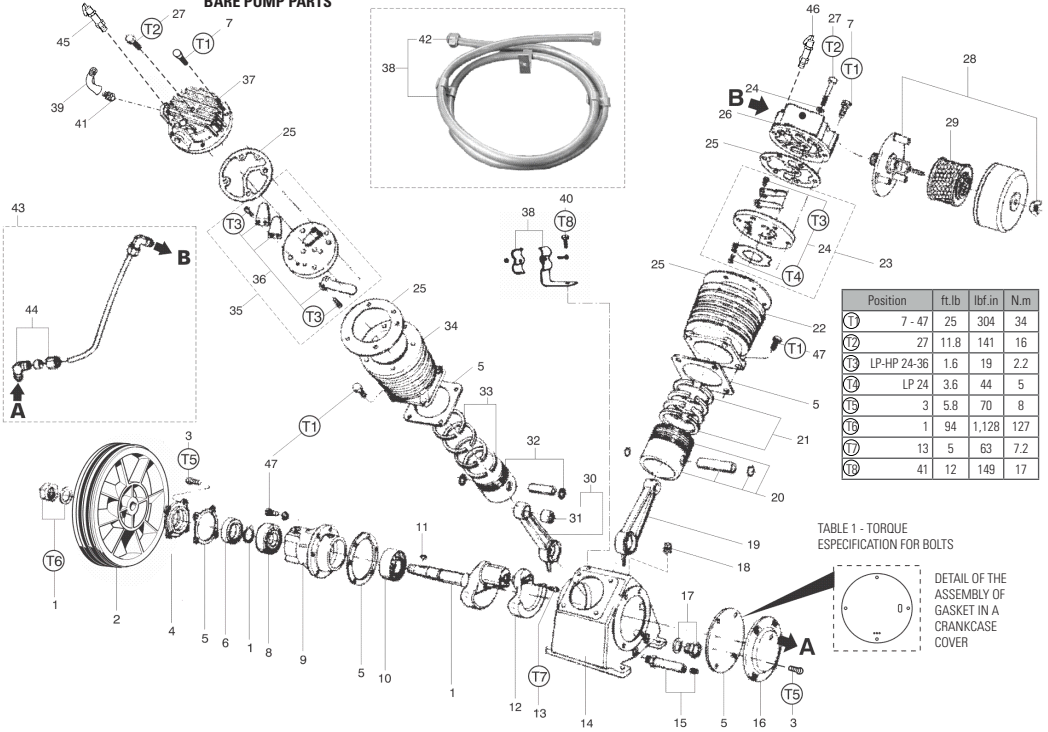

No.	CODE	DENOMINATION	QTY
1	830.0609-9	Crankshaft	01
2	709.1277-0	Flywheel	01
3	*	UNC 1/4" x 3/4" LT head bolt	08
4	709.0139-0	Flange cover	01
5	830.0954-0/NA	Crankcase gasket kit	01
6	023.0099-0	Oil seal	01
7	*	UNC 3/8" x 1.1/2" LT head bolt	11
8	019.0006-4	6208 bearing	01
9	709.1221-0	Flange	01
10	382.0028-3	6309 bearing	01
11	709.0147-1	Key	01
12	709.0930-8	Counter weight	01
13	013.0467-4	UNC 3/16" x 7/8" IT Allen head bolt	02
14	709.1191-0	Crankcase	01
15	830.0205-0	Oil drain tube	01
16	709.2211-0	Crankcase cover	01
17	830.0775-0	3/4" oil level sight	01
18	003.0028-4	1/4" plug	01
19	709.0732-1	LP connecting rod	01
20	016.0004-4	LP Ø 120mm piston	01
21	830.0981-0	LP 120mm ring kit	01
22	709.1192-0	LP 120mm cylinder	01
23	809.1028-0	LP 120mm valve plate	01
24	830.0955-0	LP valve plate kit	01

No.	CODE	DENOMINATION	QTY
25	830.0956-0/NA	Upper gasket kit	01
26	709.1272-0	LP 120mm cylinder cover	01
27	*	M6 x 1,0 x 55 Allen head bolt	03
28	809.2416-0	Air filter	01
29	007.0118-0	Filter element	01
30	830.0632-0	HP connecting rod with needle bearing	01
31	019.0028-0	Needle bearing	01
32	830.0608-0	HP Ø 2.1/2" piston	01
33	830.1078-0	HP 2.1/2" ring kit	01
34	709.1193-0	HP 2.1/2" cylinder	01
35	809.1029-0	HP 2.1/2" valve plate	01
36	830.0957-0	HP valve plate kit	01
37	709.1389-0	HP 2.1/2" cylinder cover	01
38	709.0283-4	Intercooler kit	01
39	003.0111-6	900 MF 3/4" elbow	03
40	*	UNC 5/16" x 5/8" LT head bolt	01
41	21011002	3/4" x 3/4" straight connection	02
42	21011004	3/4" nut for intercooler	02
43	830.0340-5	Crankcase breather tube	01
44	003.0005-5	NPT 1/8" x 1/4" elbow	02
45	022.0215-0	HP 1/8" ASME safety valve	01
46	022.0177-0	LP 1/8" ASME safety valve	01
47	*	UNC 3/8" x 1" LT head bolt	14

* Part available in the market - not sold by Schulz. HP = high pressure LP = low pressure

19. TECHNICAL DATA 7.580HV30X

MODEL	DISPLACEMENT		MAX. PRESSURE		TANK		rpm	Ø PULLEY		BELT SIZE	ELECTRIC MOTOR			DISCHARGE SIZE	OIL CAP.		WEIGHT WITH MOTOR		COLOR REF.
	cfm	l/min	psing	bar	Geom. Volume	gal		2P	inches		mm	hp	kW		VOLTAGE (V)	ml	in qt.	lbs	
7.580HV30X	30	850	175	12	300	80	960	9.0	226	2-A	7.5	5.6	Single-phase	1/2"	0,880	0,920	508	230	Black (pump) Gray (tank)
								4.5	115				230						

Compressor dimensions (inch/mm)

Height = 45/1143 ; length = 56/1422,4 ; width = 23/584

AIR COMPRESSOR PARTS

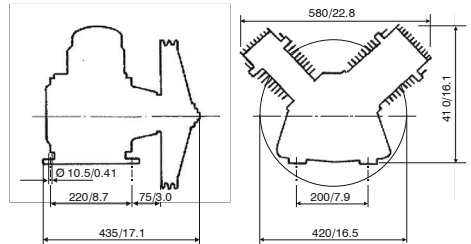
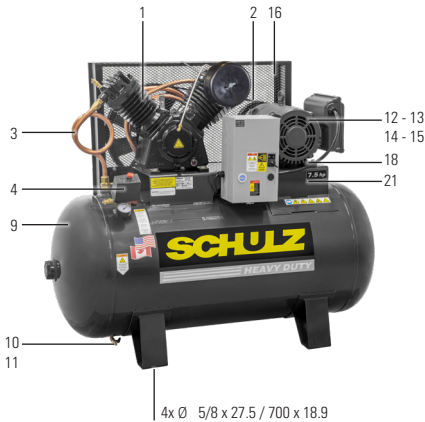

Note: dimensions in inch/mm.

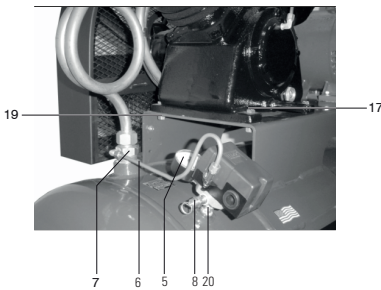

No.	CODE single-phase	CODE three-phase	DENOMINATION	QTY
1	-	-	Bare pump	01
2	830.2321-0	-	Belt guard	01
3	709.1228-0	-	Aftercooler	01
4	012.1606-0	-	Pressure switch	01
5	011.0114-0	-	Pressure gauge	01
6	709.1140-0	-	1/4" tube	01
7	022.0166-0	-	Check valve	01
8	022.0277-0	-	1/4" ASME safety valve	01
9	25003837	-	80 gal vertical tank	01
10	022.0232-0	-	1/4" tank drain valve	01
11	709.1248-0	-	Hose for tank drain (not shown)	01
12	-	015.0583-0	Motor 208/230/460V 2P	01
13	015.0616-0	-	Motor 230V 4P	01
14	709.0928-6	709.1104-0	Pulley 4P	01
15	-	709.1661-0	Pulley 2P	01
16	004.0125-0	004.0110-0	Belt	02
17	*	*	3/8" x 1.1/2" hex head	04
18	*	*	3/8" x 1.1/4" hex head	04
19	*	*	3/8" hex nut	04
20	003.0174-4	-	1/4" nipple	01
21	21028503	-	Motor fastening plate	02

* Part available in the market -not sold by Schulz.

BARE PUMP PARTS

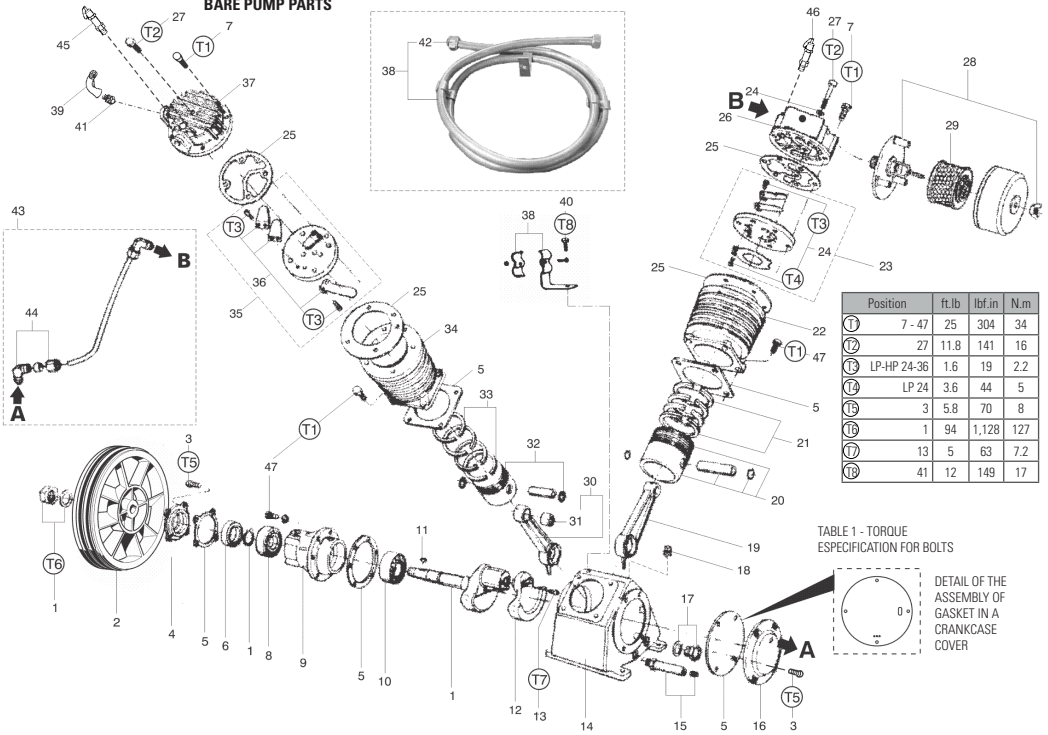

Position	ft.lb	lbf.in	N.m
T1	7 - 47	25	304
T2	27	11.8	141
T3	LP-HP 24-36	1.6	19
T3	LP 24	3.6	44
T5	3	5.9	70
T6	1	94	1,128
T7	13	5	63
T8	41	12	149

TABLE 1 - TORQUE SPECIFICATION FOR BOLTS

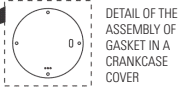

No.	CODE	DENOMINATION	QTY
1	830.0609-9	Crankshaft	01
2	709.1277-0	Flywheel	01
3	*	UNC 1/4" x 3/4" LT head bolt	08
4	709.0139-0	Flange cover	01
5	830.0954-0/NA	Crankcase gasket kit	01
6	023.0099-0	Oil seal	01
7	*	UNC 3/8" x 1.1/2" LT head bolt	11
8	019.0006-4	6208 bearing	01
9	709.1221-0	Flange	01
10	382.0028-3	6309 bearing	01
11	709.0147-1	Key	01
12	709.0930-8	Counter weight	01
13	013.0467-4	UNC 3/16" x 7/8" LT Allen head bolt	02
14	709.1191-0	Crankcase	01
15	830.0205-0	Oil drain tube	01
16	709.2211-0	Crankcase cover	01
17	830.0775-0	3/4" oil level sight	01
18	003.0028-4	1/4" plug	01
19	709.0732-1	LP connecting rod	01
20	016.0004-4	LP Ø 120mm piston	01
21	830.0981-0	LP 120mm ring kit	01
22	709.1192-0	LP 120mm cylinder	01
23	809.1028-0	LP 120mm valve plate	01

No.	CODE	DENOMINATION	QTY
24	830.0955-0	LP valve plate kit	01
25	830.0956-0/NA	Upper gasket kit	01
26	709.1272-0	LP 120mm cylinder cover	01
27	*	M6 x 1,0 x 55 Allen head bolt	03
28	809.2416-0	Air filter	01
29	007.0118-0	Filter element	01
30	830.0632-0	HP connecting rod with needle bearing	01
31	019.0028-0	Needle bearing	01
32	830.0608-0	HP Ø 2.1/2" piston	01
33	830.1078-0	HP 2.1/2" ring kit	01
34	709.1193-0	HP 2.1/2" cylinder	01
35	809.1029-0	HP 2.1/2" valve plate	01
36	830.0957-0	HP valve plate kit	01
37	709.1389-0	HP 2.1/2" cylinder cover	01
38	709.0283-4	Intercooler kit	01
39	003.0151-5	900 MF 3/4" elbow	03
40	*	UNC 5/16" x 5/8" LT head bolt	01
41	21011002	3/4" x 3/4" straight connection	02
42	21011004	3/4" nut for intercooler	02
43	830.0340-5	Crankcase breather tube	01
44	003.0005-5	NPT 1/8" x 1/4" elbow	02
45	022.0215-0	HP 1/8" ASME safety valve	01
46	022.0177-0	LP 1/8" ASME safety valve	01
47	*	UNC 3/8" x 1" LT head bolt	14

* Part available in the market - not sold by Schulz. HP = high pressure LP = low pressure

20. TECHNICAL DATA 10120HL40X

MODEL	DISPLACEMENT		MAX. PRESSURE		TANK		rpm	Ø PULLEY		BELT SIZE	ELECTRIC MOTOR			DISCHARGE SIZE	OIL CAP.		WEIGHT WITH MOTOR		COLOR REF.
	cfm	l/min	psig	bar	Geom.	Volume		2P	inches		mm	hp	kW		VOLTAGE (V)	ml	in qt.	lbs	
10120HL40X	40	1,132	175	12	427	113	1,020	5.9	150	2-A	10	7.5	Three-phase 208/230/460	1"	1,500	1,580	596	270	Black (pump) Gray (tank)

Compressor dimensions (inch/mm)

Height: 47/1193.8 ; Lenght: 78/1981.2 ; Widht: 29/736.6

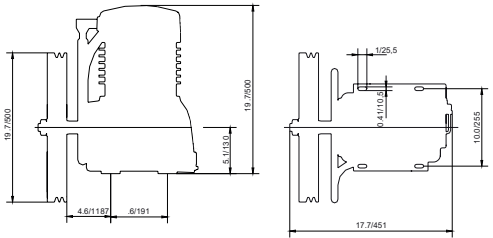

Note: dimensions in inch/mm.

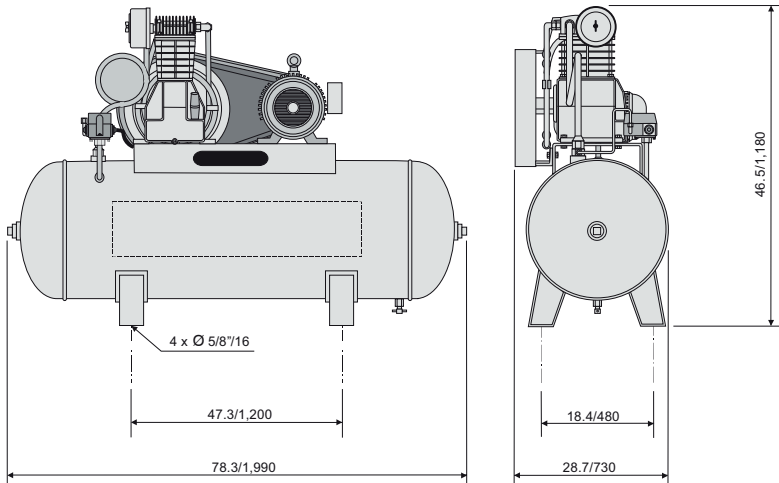

AIR COMPRESSOR PARTS

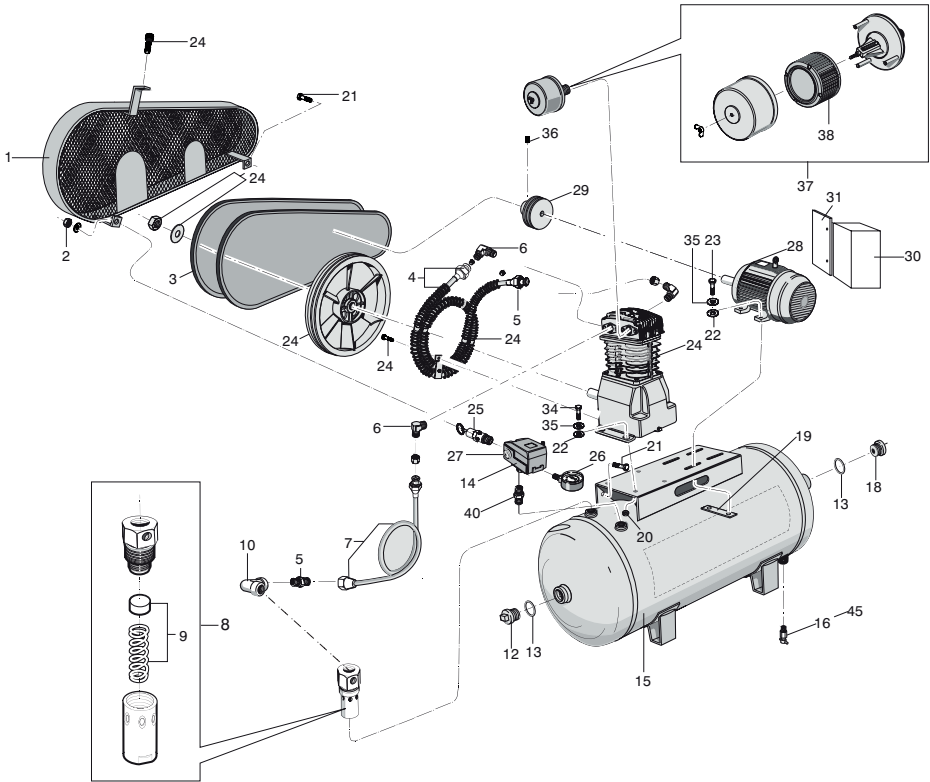

No.	CODE	DENOMINATION	QTY
1	830.2321-0	Belt guard	01
2	*	1/4" hex nut	02
3	004.0125-0	Belt	02
4	709.1663-0	Intercooler	01
5	21011002	NPT 3/4" straight connection	03
6	003.0151-5	BSP 3/4" elbow	03
7	709.1667-0	Aftercooler	01
8	60281501	Check valve	01
9	34004508	Check valve kit	01
10	003.0005-5	NPT 1/8" x 1/4" elbow	01
12	003.0514-0	2" Plug	01
13	023.0339-0	O ring	02
14	012.1606-0/AT	Pressure switch	01
15	25003832A	120 gal. horiz. tank	01
16	022.0232-0	1/4" tank drain valve	01
18	003.0556-0	2" x 1" Reduction bushing	01
19	21028503	Motor fastening plate	02
20	*	3/8" hex nut	04
21	*	1/4" x 3/4" hex head bolt	02

No.	CODE	DENOMINATION	QTY
22	*	3/8" Washer	08
23	*	3/8" x 1.1/4" hex head bolt	04
24	932.9324-0	Bare pump	01
25	022.0277-0	1/4" ASME safety valve	01
26	011.0114-0	Pressure gauge	01
27	012.0723-0	Strain relief	01
28	015.1019-0	Motor 208/230/460V (three-phase)	01
29	709.1612-0	Pulley	01
30	012.1561-0	Start switch	01
31	709.0378-0	Support start switch	01
32	012.1080-0	Start switch pressure switch cord (not shown)	01
33	012.1238-0	Motor start switch cord (not shown)	01
34	*	3/8" x 1.1/2" hex head bolt	04
35	*	3/8" lock washer	08
36	*	3/8" Allen hex without head	01
37	809.2417-0	Air filter	01
38	007.0118-0	Filter element	01
39	709.1248-0	Hose for tank drain (not shown)	01
40	003.0270-0	1/4" nipple	01

* Part available in the market -not sold by Schulz.

BARE PUMP PARTS

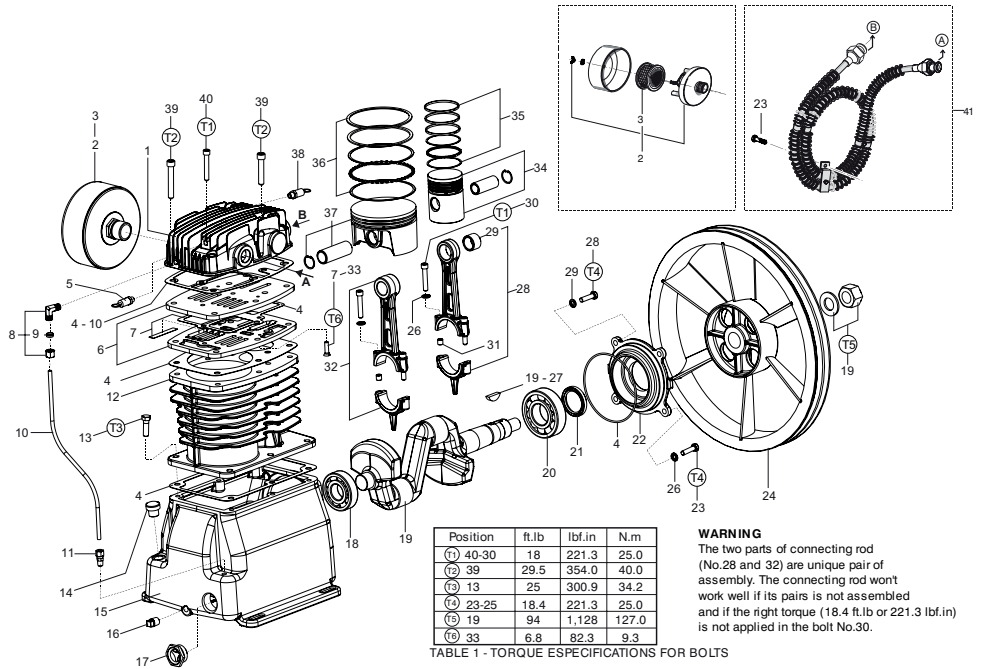

No.	CODE	DENOMINATION	QTY
1	709.1338-0	Cylinder cover	01
2	809.2417-0	1" NPT Air filter	01
3	007.0118-0	Filter element	01
4	830.1090-0/NA	Gasket kit	01
5	022.0177-0	LP 1/8" ASME safety valve	01
6	809.1787-0	Valve plate	01
7	830.1075-0	Valve plate kit	01
8	003.0005-5	NPT 1/8" x 1/4" elbow	01
9	830.0599-8	1/4" ring kit	01
10	709.1585-0	Crankcase breather tube	01
11	003.0054-3	NPT 1/8" x 1/4" straight connection	01
12	709.1708-0	Cylinder	01
13	*	3/8" x 1" Hex. head bolt	06
14	028.0297-0	M18 plug	01
15	709.1574-0	Crankcase	01
16	003.0028-4	1/4" plug	01
17	830.0154-2	1" oil level sight	01
18	019.0007-2	6306 bearing	01
19	830.1092-0	Crankshaft kit	01
20	019.0074-0	6308 bearing	01
21	60082501	Oil seal	01
22	709.1577-0	Flange	01

No.	CODE	DENOMINATION	QTY
23	*	5/16" x 1.1/4" Hex. head bolt**	01
24	709.1611-0	Flywheel	01
25	*	5/16" x 1" Hex. head bolt	03
26	*	5/16" lock washer	08
27	709.0147-1	Key	01
28	830.1093-0	HP connecting rod with needle bearing kit	01
29	019.0028-0	Needle bearing	01
30	*	5/16" x 1.3/4" Allen hex. head bolt	04
31	809.1082-C	Guide bushing connecting rod	04
32	809.1083-0	LP connecting rod kit	01
33	*	1/4" x 5/8" Flat head bolt	02
34	830.1079-0	HP Ø 2. 1/2" piston	01
35	830.1078-0	HP 2. 1/2" ring kit	01
36	830.1091-0	LP 120mm ring kit	01
37	016.0121-0	LP Ø 120mm piston	01
38	022.0215-0	HP 1/8" ASME safety valve	01
39	*	3/8" x 3" Allen hex. head bolt	08
40	*	5/16" x 2" Allen hex. head bolt	02
41	709.1663-0	Intercooler kit	01
42	0030151-5	NPT 3/4" x 3/4" elbow (not shown)	02
43	21011002	BSP 3/4" x 3/4" straight connection (not shown)	02

* Part available in the market - not sold by Schulz. ** Assembled of the intercooler holder (item 41).

Note: HP = high pressure LP = low pressure

21. TECHNICAL DATA 10120HW40X

MODEL	DISPLACEMENT		MAX. PRESSURE		TANK		RPM	Ø PULLEY		BELT SIZE	ELECTRIC MOTOR			DISCHARGE SIZE	OIL CAP.		WEIGHT WITH MOTOR		COLOR REF.
	cfm	l/min	psig	bar	l	gal		2P	inches		mm	hp	kW		VOLTAGE (V)	ml	in. qt.	lbs	
10120HW40X	40	1,132	175	12	427	113	710	4.1	105	2-B	10	7.5	Three-phase 208/230/460	1"	1,500	1,580	878	397	Black (pump) Gray (tank)

Compressor dimensions (inch/mm)

Height: 51.2/1300.5 ; Lenght: 78.3/1988.8 ; Widht: 28.7/728.9

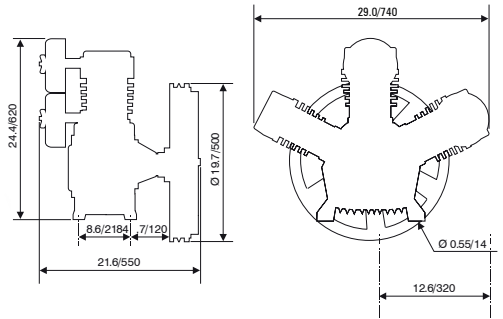

Note: dimensions in inch/mm.

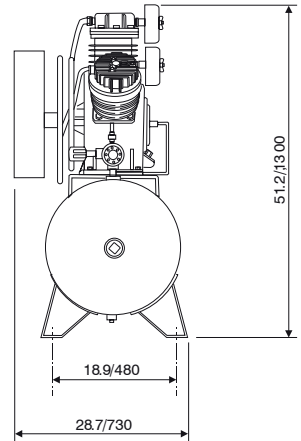
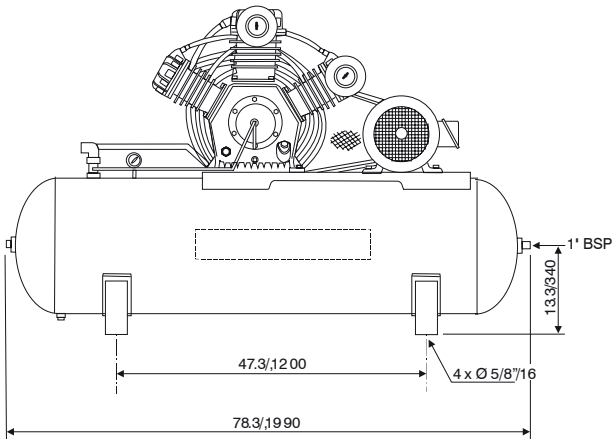

Note: dimensions in inch/mm.

AIR COMPRESSOR PARTS

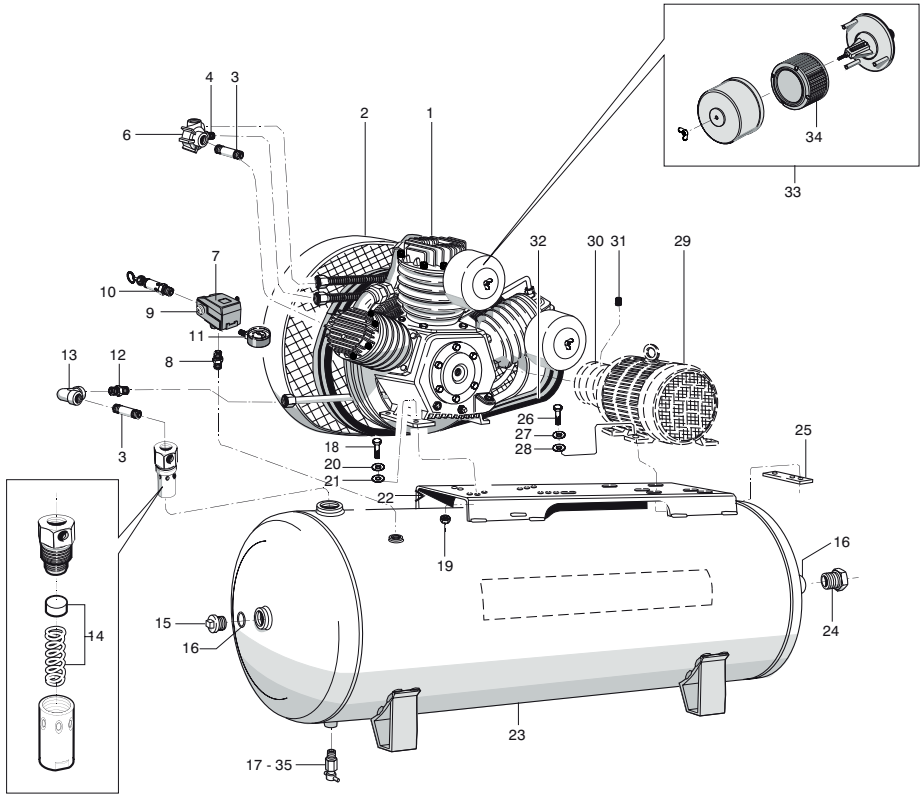

No.	CODE	DENOMINATION	QTY
1	-	Bare pump	01
2	830.2311-0	Belt guard	01
3	21011009	3/4" x 100mm nipple	02
4	21011001	NPT 3/4" x 1/2" straight connection	02
6	20517005	Upper tubing adaptor	01
7	012.1606-0/AT	Pressure switch	01
8	003.0270-0	1/4" nipple	01
9	012.0723-0	Strain relief	01
10	022.0277-0	1/4" ASME safety valve	01
11	011.0114-0	Pressure gauge	01
12	21011002	NPT 3/4" x 3/4" straight connection	02
13	003.0151-5	BSP 90° 3/4" elbow	01
14	34004508	Check valve kit	01
15	003.0514-0	2" Plug	01
16	023.0339-0	O ring	02
17	022.0232-0	1/4" tank drain valve	01
18	*	W 1/2" x 1.3/4" hex head bolt	04

No.	CODE	DENOMINATION	QTY
19	*	BSW 1/2" hex nut	04
20	*	1/2" lock washer	04
21	*	1/2" washer	04
22	701.0365-0	Support base tank	02
23	25003832A	120 gal hor. tank	01
24	003.0556-0	2" x 1" reduction bushing	01
25	21028503	Motor fastening plate	02
26	*	3/8" x 1.1/2" hex head bolt	04
27	*	3/8" lock washer	04
28	*	3/8" washer	04
29	015.1019-0	Motor 208/230/460V (three-phase)	01
30	709.1675-0	Pulley	01
31	*	5/16" x 3/8" Allen hex without head	02
32	004.0132-0	Belt	02
33	809.2416-0	3/4" NPT air filter	02
34	007.0118-0	Filter element	02
35	709.1248-0	Hose for tank drain (not shown)	01

* Part available in the market -not sold by Schulz.

** Optional start switch

BARE PUMP PARTS

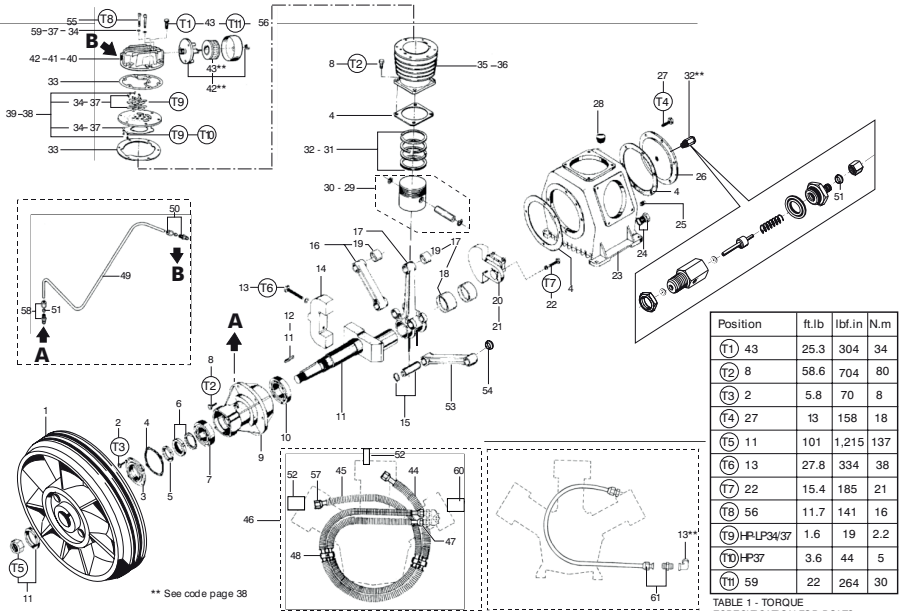

No.	CODE	DENOMINATION	QTY
1	709.1307-0	Flywheel	01
2	*	UNC 1/4" x 3/4" head bolt	04
3	20505001	Flange cover	01
4	830.1033-0/NA	Crankcase gasket kit	01
5	60082501	Oil seal	01
6	830.0932-0	Lock washer and nut kit	01
7	60154502	33109 bearing	01
8	*	NC 1/2" x 1" head bolt	18
9	20504001	Flange	01
10	60154501	32211 bearing	01
11	830.0933-0	Crankshaft kit	01
12	60267503	Key	01
13	*	UNF 3/8" x 3" head bolt	02
14	20508005	Crankshaft counter weight	01
15	830.0934-0	Auxiliary connecting rod pin kit	02
16	30008502	Connecting rod	01
17	830.0930-0	Master connecting rod	01
18	60152502	Connecting rod inner bushing	02
19	60152501	Connecting rod bushing	03
20	30007001	Counter weight with centrifugal mechanism	01
21	830.0937-0	Counter weight kit with centrifugal mechanism	01
22	*	UNF 5/16" x 1.1/4" Allen head bolt	02
23	20501002	Crankcase	01
24	830.0775-0	3/4" oil level sight kit	01
25	003.0029-2	3/8" plug	01
26	709.1316-0	Crankcase cover	01
27	*	UNC 5/16" x 3/4" head bolt	06
28	003.0031-4	3/4" plug	01
29	60273501	LP 4.3/4" piston	02
30	830.1000-0	HP 90 mm piston	01
31	000.0080-0	LP 90 mm ring kit	01

No.	CODE	DENOMINATION	QTY
32	000.0077-0	HP 4.3/4" ring kit	02
33	830.1001-0/NA	Upper gasket kit	01
34	830.1002-0	HP 90 mm valve plate kit	01
35	709.1306-0	LP 4.3/4" cylinder	02
36	709.1308-0	HP 90 mm cylinder	01
37	830.0955-0	LP 4.3/4" valve plate kit	02
38	809.1028-0	LP 4.3/4" valve plate	02
39	809.1027-0	HP 90 mm valve plate	01
40	709.1272-0	LP 4.3/4" cylinder cover with breather	01
41	709.1423-0	LP 4.3/4" cylinder cover	01
42	709.1424-0	HP 90 mm cylinder cover	01
43	*	LP UNC 3/8" x 1.1/2" head bolt	12
44	709.1322-0/C	No. 1 short intercooler	01
45	709.1322-0/L	No. 2 long intercooler	01
46	709.1322-0	Intercooler kit	01
47	21011004	3/4" nut for intercooler	04
48	21029003	Intercooler holder	02
49	830.0340-5	1/4" crankcase breather tube	01
50	003.0054-3	NPT 1/8" x 1/4" straight connection	01
51	830.0599-8	1/4" ring kit	01
52	022.0177-0	1/8" LP ASME safety valve	02
53	830.1202-0	Connecting rod with needle bearing	01
54	019.0079-0	Needle bearing	02
55	013.0752-0	M6 x 1 x 55 Allen hex bolt	05
56	383.0111-0	HP 5/16" x 1.1/2" Allen hex bolt	06
57	003.0111-6	BSP 900 3/4" elbow	02
58	60259501	Straight fitting	01
59	830.1032-0	Washer kit	01
60	022.0215-0	HP 1/8" ASME safety valve	01
61	830.1099-0	No. 3 aftercooler kit	01

* Part available in the market - not sold by Schulz. ** Assembled of the intercooler holder (item 45).
 Note: HP = high pressure LP = low pressure

22. TECHNICAL DATA 10120VW40X

MODEL	DISPLACEMENT		MAX. PRESSURE		TANK		RPM	Ø PULLEY		BELT SIZE	ELECTRIC MOTOR			DISCHARGE SIZE	OIL CAP.		WEIGHT WITH MOTOR		COLOR REF.
	cfm	l/min	psig	bar	Geom. Volume	gal		inches	mm		hp	kW	VOLTAGE (V)		Volume ml	in. qt.	lbs	Kg	
10120VW40X	40	1,132	175	12	444	117	710	4.1	105	2-B	10	7.5	Three-phase 208/230/460	1"	1,500	1,580	926	420	Black (pump) Gray (tank)

Compressor dimensions (inch/mm)

Height= 79.3/2,014; length= 49.2/1,250; width= 30/762

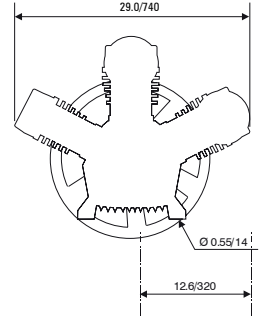
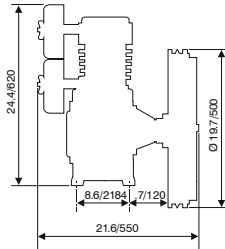
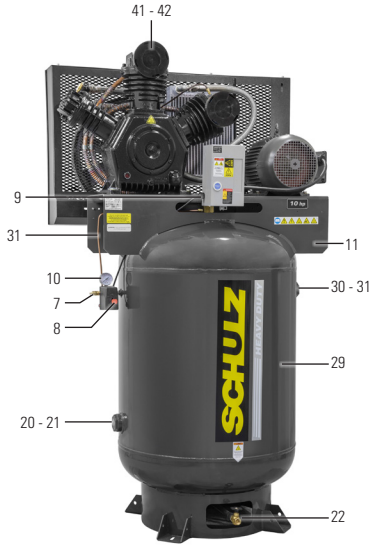

Note: dimensions in inch/mm.

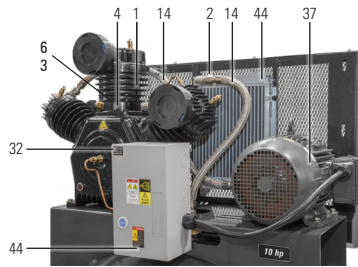

No.	CODE	DENOMINATION	QTY
1	-	Bare pump	01
2	830.2660-0	Belt guard	01
3	21011009	3/4" x 100mm nipple	01
4	21011001	NPT 3/4" x 1/2" straight connection	02
6	20517005	Upper tubing adaptor	01
7	012.1606-0	Pressure switch	01
8	003.0270-0	1/4" nipple	01
9	012.0723-0	Strain relief	01
10	022.0057-0	1/4" ASME safety valve	01
11	011.0114-0	Pressure gauge	01
12	003.0051-9	NPT 3/4" x 3/4" straight connection	01
13	003.0963-0	3/4 x 1/2 nipple	01
14	028.0939-0	Inox flexible tube 3/4 x 840	02
16	003.0964-0	3/4" nipple	02
17	60281501	Check valve	01
18	34004508	Check valve kit	01
19	003.0005-5	NPT 1/8" x 1/4" elbow connection	01
20	003.0514-0	2" Plug	01
21	023.0339-0	O ring	02
22	022.0106-2	1/2" tank drain valve	01

No.	CODE	DENOMINATION	QTY
24	*	W 1/2" x 1.3/4" hex head bolt	04
25	*	BSW 1/2" hex nut	04
26	*	1/2" lock washer	04
27	*	1/2" washer	04
28	701.0365-0	Support base tank	02
29	25004150U	120 gal vert tank	01
30	003.0556-0	2" x 1" reduction bushing	01
31	709.2160-0	1/4" tube	01
32	022.0174-0	Centrifugal unloading valve	01
33	21028503	Motor fastening plate	02
34	*	3/8" x 1.1/2" hex head bolt	04
35	*	3/8" lock washer	04
36	*	3/8" washer	04
37	015.1019-0	Motor 208/230/460V (three-phase)	01
38	709.1675-0	Pulley	01
39	*	5/16" x 3/8" Allen hex without head	02
40	004.0012-2	Belt	02
41	809.2416-0	3/4" NPT air filter	02
42	007.0118-0	Filter element	02
43	007.0103-0	After cooler	01
44	012.1561-0	Start Switch	01

* Part available in the market -not sold by Schulz.

** Optional start switch

23. TECHNICAL DATA 15120HW60X

MODEL	DISPLACEMENT		MAX. PRESSURE		TANK		RPM	Ø PULLEY		BELT SIZE	ELECTRIC MOTOR			DISCHARGE SIZE	OIL CAP.		WEIGHT WITH MOTOR		COLOR REF
	cfm	l/min	psig	bar	Geom. Volume	gal		2P	inches		mm	hp	kW		VOLTAGE (V)	Volume	in qt.	lbs	
15120HW60X	60	1,700	175	12	427	113	1,065	5.9	15	2-B	15	11.3	Three-phase 208/230/460	1"	1,500	1,580	975	442	Black (pump) Gray (tank)

Compressor dimensions (inch/mm)

Height: 51.2/1300.5 ; Length: 78.3/1988.8 ; Width: 28.7/728.9

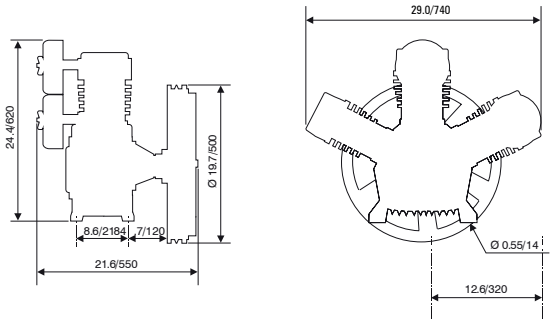

Note: dimensions in inch/mm.

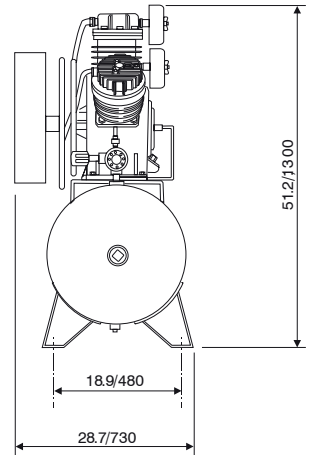
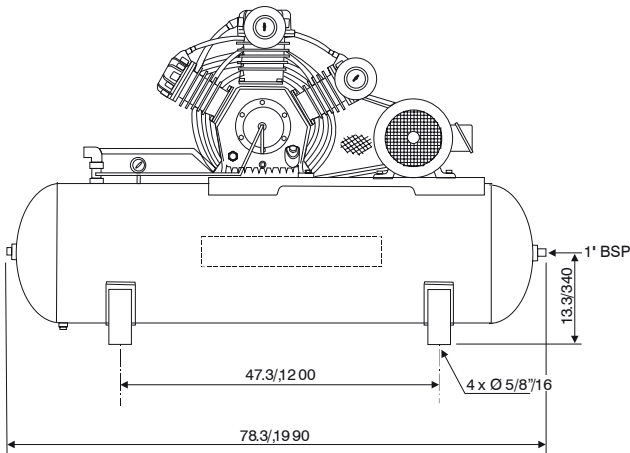

AIR COMPRESSOR PARTS

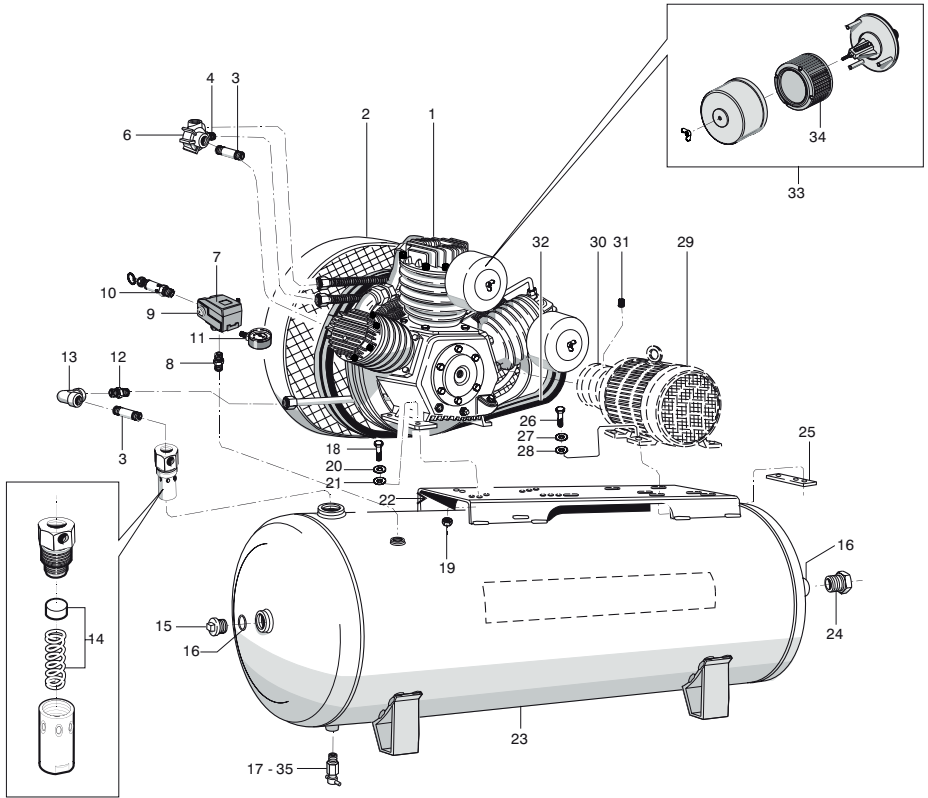

No.	CODE	DENOMINATION	QTY
1	-	Bare pump	01
2	830.2311-0	Belt guard	01
3	21011009	3/4" x 100mm nipple	02
4	21011001	NPT 3/4" x 1/2" straight connection	02
6	20517005	Upper tubing adaptor	01
7	012.1606-0/AT	Pressure switch	01
8	003.0270-0	1/4" nipple	01
9	012.0723-0	Strain relief	01
10	022.0277-0	1/4" ASME safety valve	01
11	011.0114-0	Pressure gauge	01
12	21011002	NPT 3/4" x 3/4" straight connection	02
13	003.0151-5	BSP 90° 3/4" elbow	01
14	34004508	Check valve kit	01
15	003.0514-0	2" Plug	01
16	023.0339-0	O ring	02
17	022.0232-0	1/4" tank drain valve	01
18	*	W 1/2" x 1.3/4" hex head bolt	04

No.	CODE	DENOMINATION	QTY
19	*	BSW 1/2" hex nut	04
20	*	1/2" lock washer	04
21	*	1/2" washer	04
22	701.0365-0	Support base tank	02
23	25003832A	120 gal hor. tank	01
24	003.0556-0	2" x 1" reduction bushing	01
25	21028503	Motor fastening plate	02
26	*	3/8" x 1.1/2" hex head bolt	04
27	*	3/8" lock washer	04
28	*	3/8" washer	04
29	015.1019-0	Motor 208/230/460V (three-phase)	01
30	709.1675-0	Pulley	01
31	*	5/16" x 3/8" Allen hex without head	02
32	004.0132-0	Belt	02
33	809.2416-0	3/4" NPT air filter	02
34	007.0118-0	Filter element	02
35	709.1248-0	Hose for tank drain (not shown)	01

* Part available in the market -not sold by Schulz.

BARE PUMP PARTS

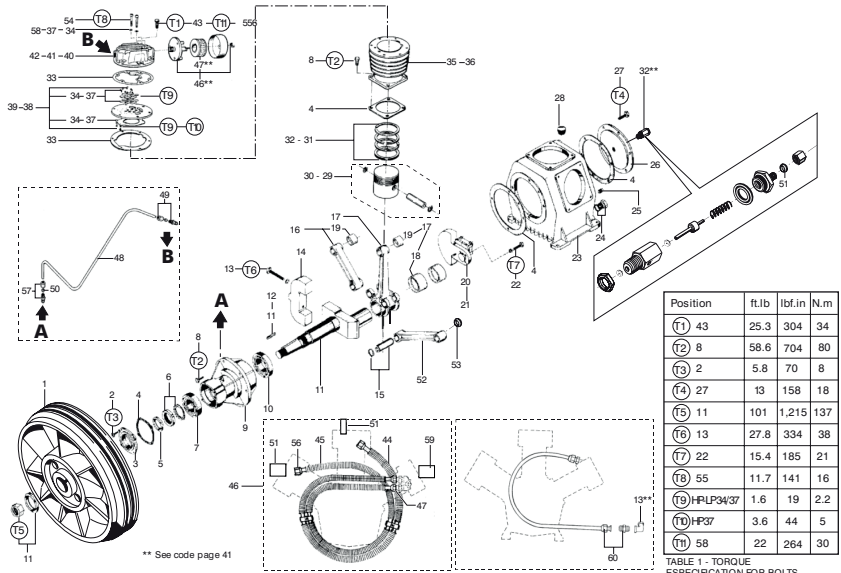

Position	ft.lb	lbf.in	N.m
(T1) 43	25.3	304	34
(T2) 8	58.6	704	80
(T3) 2	5.8	70	8
(T4) 27	13	158	18
(T5) 11	101	1,215	137
(T6) 13	27.8	334	38
(T7) 22	15.4	185	21
(T8) 55	11.7	141	16
(T9) HP-PLP3/37	1.6	19	2.2
(T10) FP37	3.6	44	5
(T11) 58	22	264	30

TABLE 1. TORQUE SPECIFICATION FOR BOLTS

No.	CODE	DENOMINATION	QTY
1	709.1307-0	Flywheel	01
2	*	UNC 1/4" x 3/4" head bolt	04
3	20505001	Flange cover	01
4	830.1033-0/NA	Crankcase gasket kit	01
5	60082501	Oil seal	01
6	830.0932-0	Lock washer and nut kit	01
7	60154502	33109 bearing	01
8	*	NC 1/2" x 1" head bolt	18
9	20504001	Flange	01
10	60154501	32211 bearing	01
11	830.0933-0	Crankshaft kit	01
12	60267503	Key	01
13	*	UNF 3/8" x 3" head bolt	02
14	20508009	Crankshaft counter weight	01
15	830.0934-0	Auxiliary connecting rod pin kit	02
16	30008502	Connecting rod	01
17	830.0930-0	Master connecting rod	01
18	60152502	Connecting rod inner bushing	02
19	60152501	Connecting rod bushing	03
20	30007001	Counter weight with centrifugal mechanism	01
21	830.0937-0	Counter weight kit with centrifugal mechanism	01
22	*	UNF 5/16" x 1.1/4" Allen head bolt	02
23	20501002	Crankcase	01
24	830.0775-0	3/4" oil level sight kit	01
25	003.0029-2	3/8" plug	01
26	709.1316-0	Crankcase cover	01
27	*	UNC 5/16" x 3/4" head bolt	06
28	003.0031-4	3/4" plug	01
29	60273501	LP 4.3/4" piston	02
30	830.1000-0	HP 90 mm piston	01
31	000.0080-0	LP 90 mm ring kit	01

No.	CODE	DENOMINATION	QTY
32	000.0077-0	HP 4.3/4" ring kit	02
33	830.1001-0/NA	Upper gasket kit	01
34	830.1002-0	HP 90 mm valve plate kit	01
35	709.1306-0	LP 4.3/4" cylinder	02
36	709.1308-0	HP 90 mm cylinder	01
37	830.0955-0	LP 4.3/4" valve plate kit	02
38	809.1028-0	LP 4.3/4" valve plate	02
39	809.1027-0	HP 90 mm valve plate	01
40	709.1272-0	LP 4.3/4" cylinder cover with breather	01
41	709.1423-0	LP 4.3/4" cylinder cover	01
42	709.1424-0	HP 90 mm cylinder cover	01
43	*	LP UNC 3/8" x 1.1/2" head bolt	12
44	709.1322-0/C	No. 1 short intercooler	01
45	709.1322-0/L	No. 2 long intercooler	01
46	709.1322-0	Intercooler kit	01
47	21011004	3/4" nut for intercooler	04
48	830.0340-5	1/4" crankcase breather tube	01
49	003.0054-3	NPT 1/8" x 1/4" straight connection	01
50	830.0599-8	1/4" ring kit	01
51	022.0177-0	1/8" LP ASME safety valve	02
52	830.1202-0	Connecting rod with needle bearing	01
53	019.0079-0	Needle bearing	02
54	013.0752-0	M6 x 1 x 55 Allen hex bolt	05
55	*	HP 5/16" x 1.1/2" Allen hex bolt	06
56	003.0111-6	BSP 900 3/4" elbow	02
57	60259501	Straight fitting	01
58	830.1032-0	Washer kit	01
59	022.0215-0	HP 1/8" ASME safety valve	01
60	830.1099-0	No. 3 aftercooler kit	01

* Part available in the market - not sold by Schulz. ** Assembled of the intercooler holder (item 45).
 Note: HP = high pressure LP = low pressure

24. TECHNICAL DATA 15120VW60X

MODEL	DISPLACEMENT		MAX. PRESSURE		TANK		rpm	Ø PULLEY		BELT SIZE	ELECTRIC MOTOR			DISCHARGE SIZE	OIL CAP.		WEIGHT WITH MOTOR		COLOR REF
	cfm	l/min	psig	bar	Geom. Volume	gal		2P	inches		mm	hp	kW		VOLTAGE (V)	Volume	ml	in qt.	
15120VW60X	40	1,132	175	12	444	117	710	4.1	105	2-B	10	7.5	Three-phase 208/230/460	1"	1,500	1,580	952	432	Black (pump) Gray (tank)

Compressor dimensions (inch/mm)

Height= 79.3/2,014; length= 49.2/1,250; width= 30/762

AIR COMPRESSOR PARTS

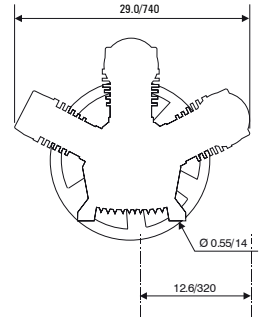
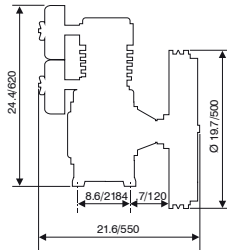
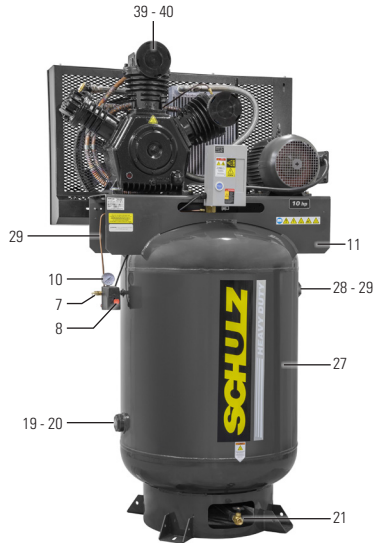

Note: dimensions in inch/mm.

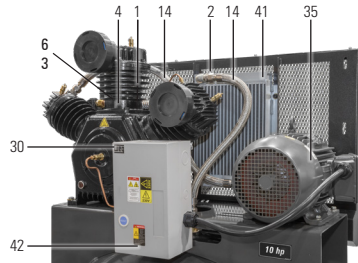

No.	CODE	DENOMINATION	QTY
1	-	Bare pump	01
2	830.2660-0	Belt guard	01
3	21011009	3/4" x 100mm nipple	01
4	21011001	NPT 3/4" x 1/2" straight connection	02
6	20517005	Upper tubing adaptor	01
7	012.1606-0	Pressure switch	01
8	003.0270-0	1/4" nipple	01
9	012.0723-0	Strain relief	01
10	022.0057-0	1/4" ASME safety valve	01
11	011.0114-0	Pressure gauge	01
12	003.0051-9	NPT 3/4" x 3/4" straight connection	01
13	003.0963-0	3/4 x 1/2 nipple	02
14	028.0939-0	Inox flexible tube 3/4 x 840	02
15	003.0964-0	3/4" nipple	02
16	60281501	Check valve	01
17	34004508	Check valve kit	01
18	003.0005-5	NPT 1/8" x 1/4" elbow connection	01
19	003.0514-0	2" Plug	01
20	023.0339-0	O ring	02
21	022.0106-2	1/2" tank drain valve	01

No.	CODE	DENOMINATION	QTY
22	*	W 1/2" x 1.3/4" hex head bolt	04
23	*	BSW 1/2" hex nut	04
24	*	1/2" lock washer	04
25	*	1/2" washer	04
26	701.0365-0	Support base tank	02
27	25004150U	120 gal vert. tank	01
28	003.0556-0	2" x 1" reduction bushing	01
29	709.2160-0	1/4" tube	01
30	022.0174-0	Centrifugal unloading valve	01
31	21028503	Motor fastening plate	02
32	*	3/8" x 1.1/2" hex head bolt	04
33	*	3/8" lock washer	04
34	*	3/8" washer	04
35	015.1020-0	Motor 208/230/460V (three-phase)	01
36	709.1325-0	Pulley	01
37	*	5/16" x 3/8" Allen hex without head	02
38	004.0132-0	Belt	02
39	809.2416-0	3/4" NPT air filter	02
40	007.0118-0	Filter element	02
41	007.0103-0	Aftercooler	01
42	012.1562-0	Start Switch	01

* Part available in the market -not sold by Schulz.

25. TECHNICAL DATA 20120HWV80X

MODEL	DISPLACEMENT		MAX. PRESSURE		TANK		rpm	Ø PULLEY		BELT SIZE	ELECTRIC MOTOR			DISCHARGE SIZE	OIL CAP.		WEIGHT WITH MOTOR		COLOR REF.
	cfm	l/min	psig	bar	Geom. Volume	gal		2P	2P		hp	kW	VOLTAGE (V)		Volume	Volume	lbs	Kg	
					l		inches	mm	2P						ml	in qt.			
20120HWV80X	80	2,264	175	12	427	113	910	5.7	145	2-B	20	15	Three-phase 208/230/460	1"	4,500	4,620	1,370	620	Black (pump) Gray (tank)

Compressor dimensions (inch/mm)

Height: 57.5/1460.5 ; Lenght: 78.3/1988.8 ; Widht: 28.7/728.9

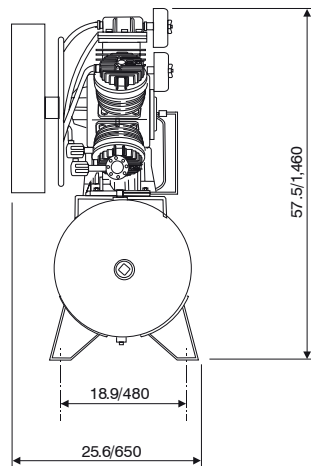
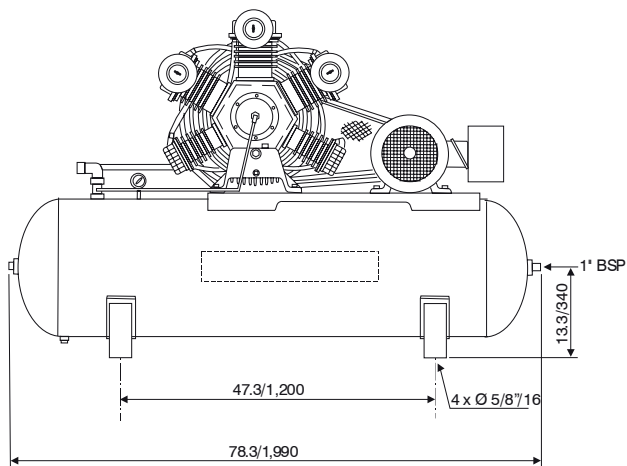
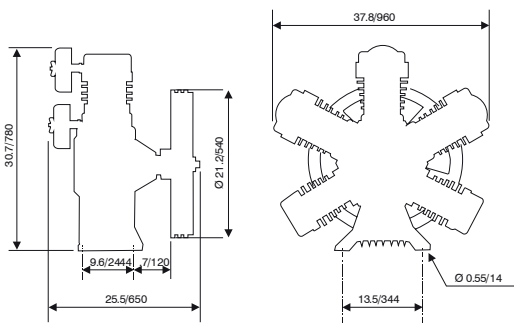
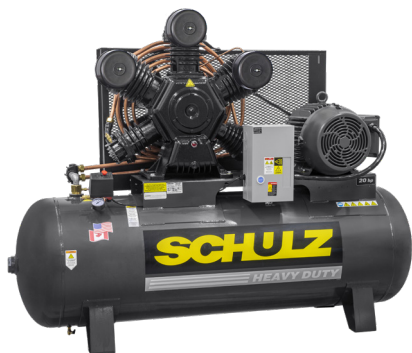

AIR COMPRESSOR PARTS

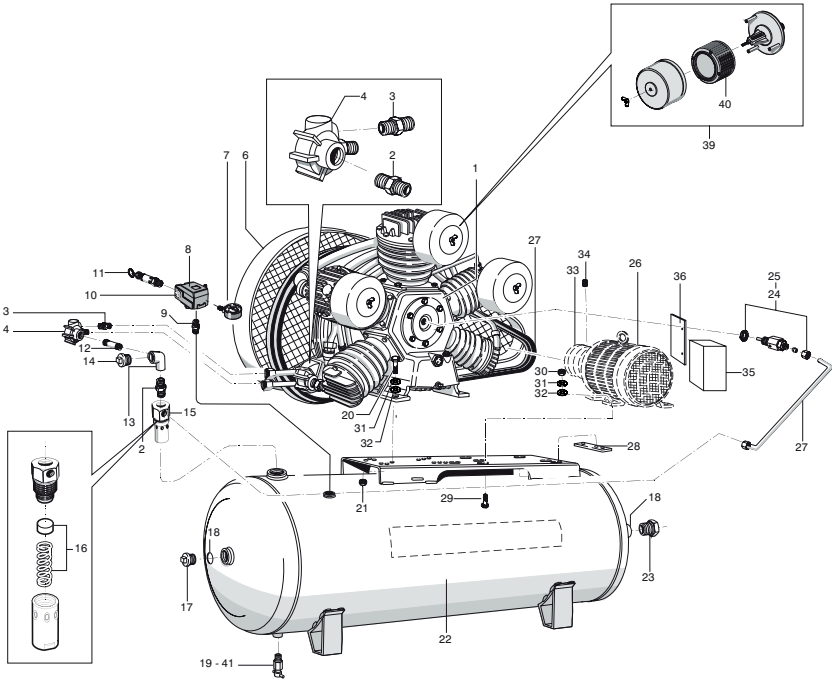

No.	CODE	DENOMINATION	QTY
1	933.9385-0	Bare pump	01
2	003.0509-0	3/4" nipple	02
3	21011001	NPT 3/4" x 1/2" straight connection	04
4	20517005	Upper tubing adaptor	02
6	830.2311-0	Belt guard	01
7	011.0114-0	Pressure gauge	01
8	012.1606-0	Pressure switch	01
9	003.0270-0	1/4" nipple	01
10	012.0723-0	Strain relief	01
11	022.0277-0	1/4" ASME safety valve	01
12	21011006	3/4" x 126mm nipple	01
13	003.0151-5	3/4" side elbow	01
14	003.0031-4	3/4" plug	01
15	60281501	Check valve	01
16	34004508	Check valve kit	01
17	003.0514-0	2" Plug	01
18	023.0339-0	O - ring	02
19	022.0232-0	1/4" tank drain valve	01
20	*	W 1/2" x 1.1/2" hex head bolt	04
21	*	BSW 1/2" hex nut	04

No.	CODE	DENOMINATION	QTY
22		120 gal. horiz. Tank	01
23	003.0556-0	2" x 1" reduction bushing	01
24	022.0174-0	Centrifugal unloading valve	01
25	830.1043-0	Centrifugal unloading valve kit	01
26	015.1021-0	Motor 208/230/460V (three-phase)	01
27	004.0022-0	Belt	02
28	21028539	Motor fastening plate	02
29	*	7/16" x 1.3/4" hex head bolt	04
30	*	7/16" hex nut	04
31	*	1/2" lock washer	08
32	*	1/2" washer	08
33	709.1349-0	Pulley	01
34	*	3/8" x 1/2" Allen hex without head	01
35	012.1563-0	Start switch	01
36	701.0377-0	Support start switch	01
37	012.1213-0	Start switch pressure switch cord (not shown)	01
38	012.1228-0	Motor start switch cord (not shown)	01
39	809.2416-0	3/4" NPT air filter	03
40	007.0118-0	Filter element	03
41	709.1248-0	Hose for tank drain (not shown)	01

* Part available in the market -not sold by Schulz.

** Optional start switch

BARE PUMP PARTS

Position	ft.lb	lbf.in	N.m
(T1)	49	25	304 34
(T2)	8	58	704 80
(T3)	2	5.8	70 8
(T4)	28	13	158 18
(T5)	12	101	1,215 137
(T6)	14	27.8	334 38
(T7)	23	15	185 21
(T8)	61	12	141 16
(T9) HPLP 40-41-50	1.6	19	2.2
(T10) LP 40-41-50	3.6	44	5
(T11)	58	22	264 30

TABLE 1 - TORQUE SPECIFICATION FOR BOLTS

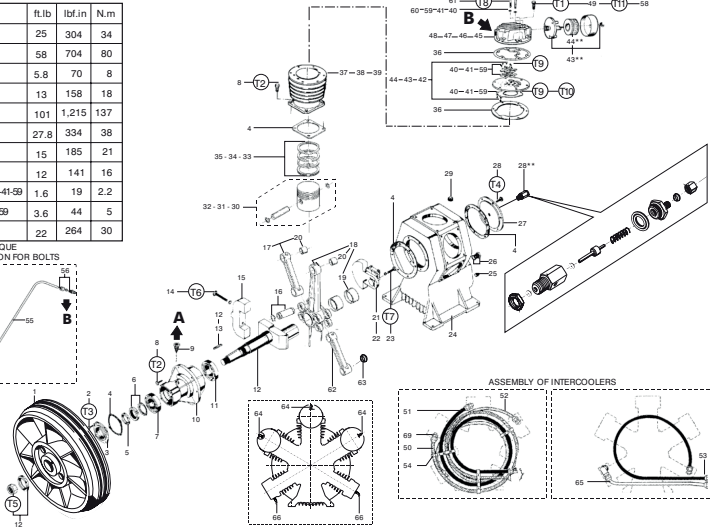
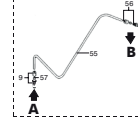

No.	CODE	DENOMINATION	QTY
1	709.1346-0	Flywheel	01
2	*	UNC 1/4" x 3/4" head bolt	04
3	20505001	Flange cover	01
4	830.1033-0/NA	Crankcase gasket kit	01
5	60082501	Oil seal	01
6	830.0932-0	Lock washer and nut kit	01
7	60154502	33109 bearing	01
8	*	NC 1/2" x 1" head bolt	26
9	60259501	Straight fitting	01
10	20504001	Flange	01
11	60154501	32211 bearing	01
12	830.0933-0	Crankshaft kit	01
13	60267503	Key	01
14	*	UNF 3/8" x 3" head bolt	02
15	20508011	Crankshaft counter weight	01
16	830.0934-0	Connecting rod pin kit	04
17	30008502	Connecting rod	03
18	830.0938-0	Master connecting rod	01
19	60152502	Connecting rod inner bushing	02
20	60152501	Connecting rod bushing	07
21	30007007	Counter weight with centrifugal mechanism	01
22	830.0937-0	Counter weight kit with centrifugal mechanism	01
23	*	UNF 5/16" x 1.1/4" Allen head bolt	02
24	20501001	Crankcase	01
25	003.0029-2	3/8" plug	01
26	830.0775-0	3/4" oil level sight kit	01
27	709.1316-0	Crankcase cover	01
28	*	UNC 5/16" x 3/4" head bolt	06
29	003.0031-4	3/4" plug	01
30	60273501	LP 4.3/4" piston	03
31	830.1000-0	HP 90mm piston kit	01
32	830.0939-0	HP 2.1/2" piston kit	01
33	000.0077-0	LP 4.3/4" ring kit	03
34	000.0080-0	HP 90mm ring kit	01

No.	CODE	DENOMINATION	QTY
35	000.0075-0	HP 2.1/2" ring kit	01
36	830.1031-0/NA	Upper gasket kit	01
37	709.1306-0	LP 4.3/4" cylinder	03
38	709.1308-0	HP 90mm cylinder	01
39	709.1347-0	HP 2.1/2" cylinder	01
40	830.0955-0	LP 4.3/4" valve plate kit	03
41	830.1002-0	HP 90 mm valve plate kit	01
42	809.1028-0	LP 4.3/4" valve plate	03
43	809.1027-0	HP 90mm valve plate	01
44	809.1029-0	HP 2.1/2" valve plate	01
45	709.1272-0	LP 4.3/4" cylinder cover (with breather)	01
46	709.1423-0	LP 4.3/4" cylinder cover (without breather)	02
47	709.1424-0	HP 90mm cylinder cover	01
48	709.1389-0	HP 2.1/2" cylinder cover	01
49	*	UNC 3/8" x 1.1/2" head bolt	23
50	809.1043-0	Short intercooler No. 2	01
51	809.1043-0	Medium intercooler No. 3	01
52	809.1043-0	Long intercooler No. 4	01
53	21011004	3/4" nut for intercooler	10
54	21029003	Intercooler holder	03
55	830.0340-5	1/4" crankcase breather tube	01
56	003.0054-3	1/8" x 1/4" straight connection	01
57	830.0599-8	1/4" ring kit	01
58	383.0111-0	HP 5/16" x 1.1/2" Allen hex bolt	06
59	830.0957-0	HP 2.1/2" valve plate kit	01
60	830.1032-0	Washer kit	01
61	013.0752-0	M6 x 1 x 55 Allen hex bolt	08
62	830.1202-0	Connecting rod with needle bearing	01
63	019.0079-0	Needle bearing	02
64	022.0177-0	LP 1/8" ASME safety valve	03
65	709.1369-0	Discharge tube No. 1	01
66	022.0215-0	HP 1/8" ASME safety valve	02
67	21011002	3/4" x 3/4" straight connection	06

* Part available in the market - not sold by Schulz. ** Assembled of the intercooler holder (item 45).

Note: HP = high pressure LP = low pressure

26. TECHNICAL DATA MCSV-20 HEAVY DUTY

MODEL	DISPLACEMENT		MAXIMUM PRESSURE		AIR RECEIVER TANK		ELECTRIC MOTOR				DIMENSIONS (INCH/M.M)										AIR DISCHARGE CONNECTION	OIL CAP. ml	WEIGHT		COLOR REF.		
	cfm	l/min.	psig	bar	Geom. Volume l gal	Rpm	hp	KW	Hz	Poles	Voltage (V)	A	B	C	D	E	F	G	H	I			J	lbs		Kg	
MCSV-20 AP Three-phase	20	566.4	175	12	300	80	1710	5	3.7	60	4	230	67/1886	24/609	30/759	24/602	18.5/470	18.5/470	0.5/12	0.7/16	12/304	38/964	3/4"	1200	363.8	165	Black (Pump)
MCSV-20 AP Single-phase							1750						385.8												175	Gray (Tank)	

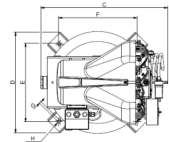
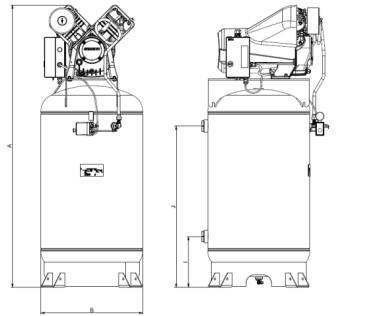
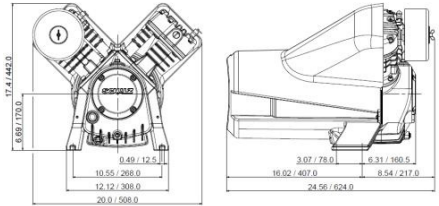
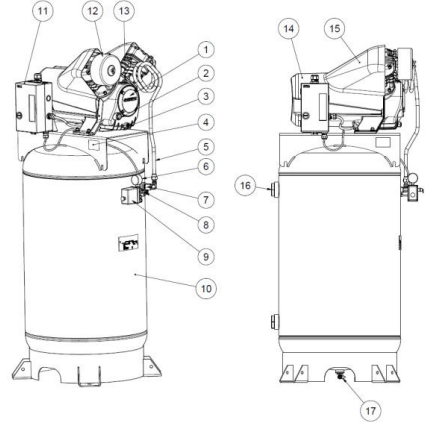

N°	CODE	DENOMINATION	QTY.
1	932.7559-0	Barepump CMSV 20 AP 230V (Threphase)	1
1.1	932.7558-0	Barepump CMSV 20 AP 230V (Single-phase)	1
2	830.0775-0/AT	3/4" oil level sight	1
3	003.0216-3	1/4" plug	1
4	-	Air compressor Identification	1
5	028.0979-0/AT	Discharge pipe	1
6	830.1673-0	Pressure gauge	1
7	60281012/AT	Check valve	1
8	022.0162-0/AT	1/4" ASME safety valve	1
9	012.1606-0/AT	Pressure switch	1
10	25004146LU/CZ/A	80 gal vertical tank	1
11	012.1560-0/AT	Three Phase electrical starter	1
11.1	012.2293-0/AT	Single Phase electrical starter	1
12	809.2416-0	Air filter (3/4 NPT Coupling thread)	1
12.1	830.1257-0	Air Filter element	1
13	003.0031-4/AT	3/4" plug	1
14	015.1168-0/AT	Three Phase Electric motor 230V 60Hz	1
14.1	015.1194-0/AT	Single Phase Electric motor 230V 60Hz	1
15	028.0776-0/AT	Three Phase Protection cover	1
15.1	028.0942-0/AT	Single Phase Protection cover	1
16	809.1926-0/AT	1/4" tank drain valve	1
17	709.1248-0/AT	Hose for tank drain	1

BARE PUMP PARTS

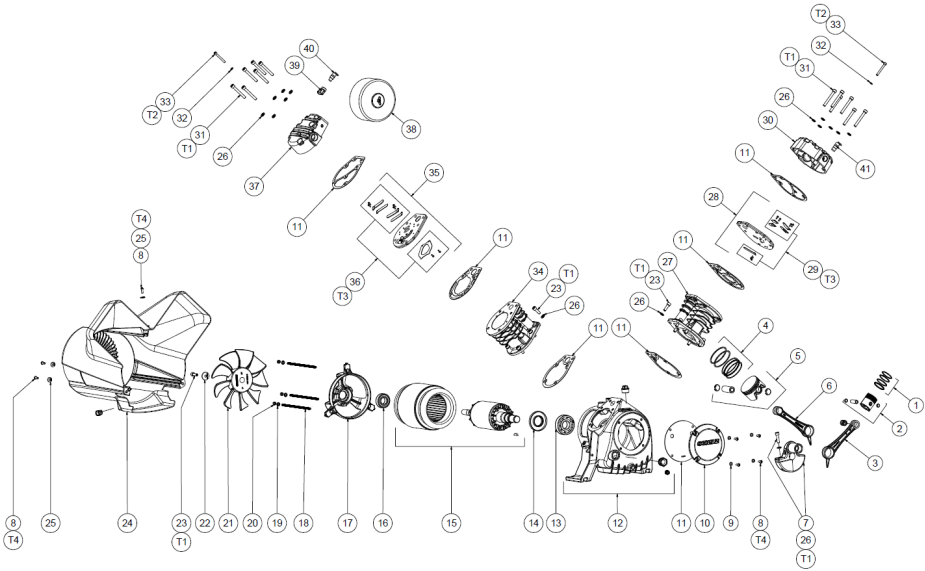

SCREW LIST - Applying torque values				
Number	TORK		DENOMINATION	
	-	N.m		
23	T1	33	288,8	M8- 1,25 x 25 mm
31	T1			M8- 1,25 x 65 mm
7	T1			M8- 1,25 x 30 mm
33	T2	12	105	M6- 1 x 50 mm
29/36	T2	2,2	19,25	M3- 0,5 x 8 mm
8	T2	12	105	M6- 1 x 16 mm

N°	CODE	DENOMINATION	QTY.
1	830.1268-0	Piston Ring Set (High Pressure)	1
2	701.0416-0/AT	Piston (High Pressure)	1
3	830.1269-0	Connecting rod (High Pressure)	1
		Needle bearing	1
4	830.1229-0/AT	Piston Ring Set (Low Pressure)	1
5	016.0123-0/AT	Piston (Low Pressure)	1
6	709.2053-0/AT	Connecting rod (Low Pressure)	1
7	709.2065-0/AT	Crankshaft	1
		Socket Head Cap Screws M8 1,25 x 30mm, Class 12.9	1
		Lock washer Nd = 8 mm	1
8	*	Button Head Screw M6 1 x 16 mm, Class 12.9	7
9	*	Flat washer Nominal diameter = 6,5 mm x External diameter = 12 mm	1
10	830.2662-0	Front cover assembly	1
11	830.2621-0	Sealing assembly	1
12	830.2622-0	Crankcase	1
		Bushing	1
		Pressure Plug 1/4" BSP	1
		Pressure Plug 3/4" BSP	1
13	019.0111-0/AT	Bearing	1
14	023.0500-0/AT	Oil seal	1
15	015.1168-0/AT	Three Phase Electric motor 230V 60Hz	1
15.1	015.1194-0/AT	Single Phase Electric motor 230V 60Hz	1
16	019.0117-0/AT	Bearing	1

N°	CODE	DENOMINATION	QTY.
17	709.2064-0/AT	Electric motor cover	1
18	*	M6- 1 x 200 mm screw rod. (three phase) / M6- 1 x 220 mm screw rod. (Single phase)	3
19	*	Lock washer Nd = 6 mm	3
20	*	Hex nut M6 - 1	3
21	709.2066-0/AT	Propeller	1
22	*	Flat washer Nominal diameter = 8 mm x External diameter = 29 mm	1
23	*	Socket Head Cap Screws M8 1,25 x 25mm, Class 12.9	13
24	028.0776-0/AT	Protection cover (Three Phase)	1
		Cable gland	1
24.1	028.0942-0/AT	Protection cover (Single Phase)	1
24.1	028.0942-0/AT	Electrical conduit	1
		Flat washer Nominal diameter = 7 mm x External diameter = 17 mm	3
25	*	Flat washer Nominal diameter = 7 mm x External diameter = 17 mm	3
26	*	Lock washer Nd = 8 mm	25
27	709.2058-0/AT	Cylinder (High Pressure)	1
28	830.2669-0	Valve plate assembly (High Pressure)	1
29	830.2624-0	Valve plate repair (High Pressure)	1
30	709.2126-0/AT	Cylinder cover (High Pressure)	1
31	*	Hex head bolt M8 - 1,25 x 65 mm, Class 12.9	12
32	*	Copper flat washer , Nd = 6,5 mm x Ed = 11 mm	2
33	*	Socket Head Cap Screws M6 1 x 50mm, Class 12.9	2
34	709.2125-0/AT	Cylinder (Low Pressure)	1
35	830.2663-0	Valve plate (Low Pressure)	1
36	830.2626-0	Valve plate repair (Low Pressure)	1
37	709.2128-0/AT	Cylinder cover (Low Pressure)	1
38	809.2416-0	Air filter (3/4 NPT Coupling thread)	1
38.1	007-0118-0	Air filter element	1
39	*	Elbow 1/8 NPT (Male female)	1
40	022.0177-0	HP 1/8" ASME safety valve	1
41	022.0215-0	HP 1/4" ASME safety valve	1

*Part available in the market (not sold by Schulz).

Follow the guideline for proper installation of the product, the electrical installation is the responsibility of the user (owner).

3- Check the fan direction, which should be clockwise as shown in the figure (B).

1 - Remove the three fixing screws on the protective cover as shown below.

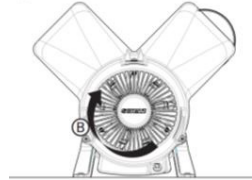
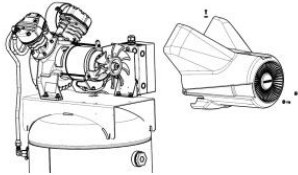
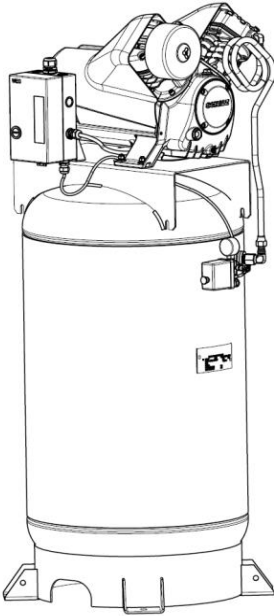

2- The motor must be grounded in accordance with national regulations to prevent electric shock.

Make the electrical connection according to the electrical diagram on the next pages and connect the grounding cable as indicated in the point (A).

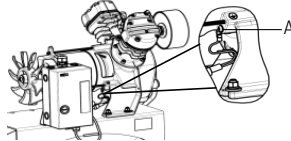

4 - For the motor connecting, feed the cable through the hole in the protection cover and use the cable gland to clamping it. (Figure C)

Then connect the cable to the pressure switch according indicated in the point (D).

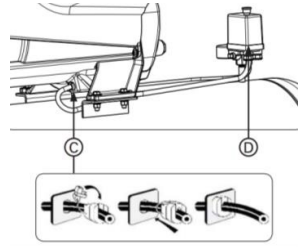

5 - Three phase electric motor connections.

1710 rpm	1 SF	230 V	
5 cv - hp	3 ~	16.5 A	
3,7 kW	60 Hz		
S3 70% Duty	1000 Alt. Max		

6 - Single phase electric motor connections.

1750 rpm	1.2 SF	
5 cv - hp	1 ~	
3,7 kW	60 Hz	
S3 70% Duty	1000 Alt. Max	
		5 HP 208-230V 22,8-23,0 A 60 Hz 1750 rpm

ELECTRICAL CONNECTION - CUSTOMER RESPONSIBILITY

ELECTRICAL THREE PHASE DIAGRAM WITH STARTER SWITCH

<p>SUPPLY VOLTAGE 208 240V 60Hz FUSES UNDER CUSTOMER RESPONSIBILITY</p>	<p>SINGLE PHASE MOTOR (STANDARD) DIRECT STARTER</p>	<p>ON/OFF</p>
--	--	----------------------

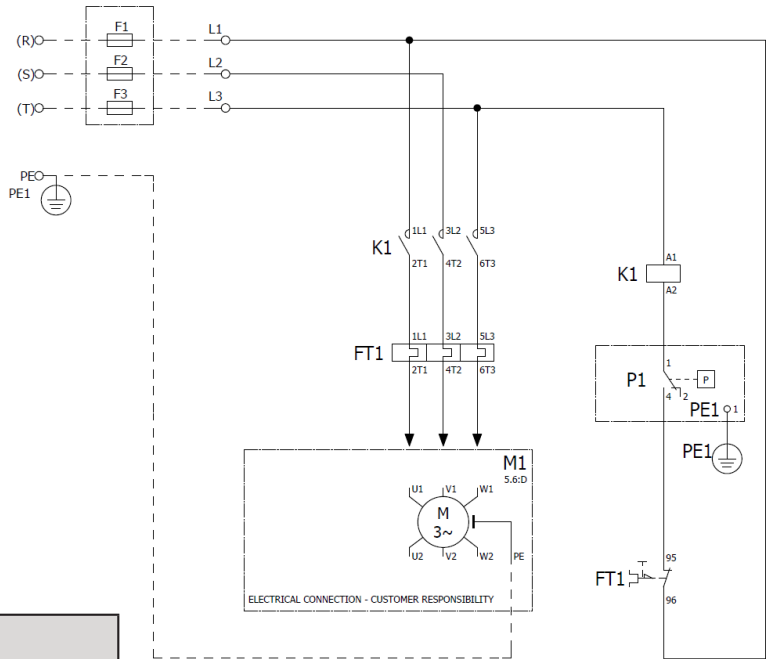

SUBTITLE	
COMPONENT	DESCRIPTION
	TREE-POLE CONTACTOR
	ELECTRIC MOTOR
	OVERLOAD RELAY
	SUPPLY FUSE
	PRESSURE SWITCH
	GROUND

THREE PHASE ELECTRICAL STARTER SWITCH

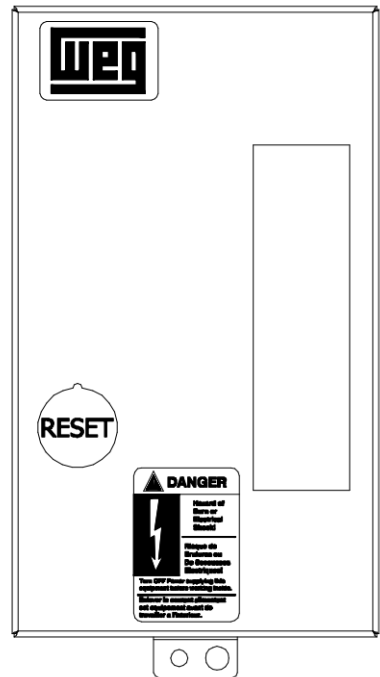
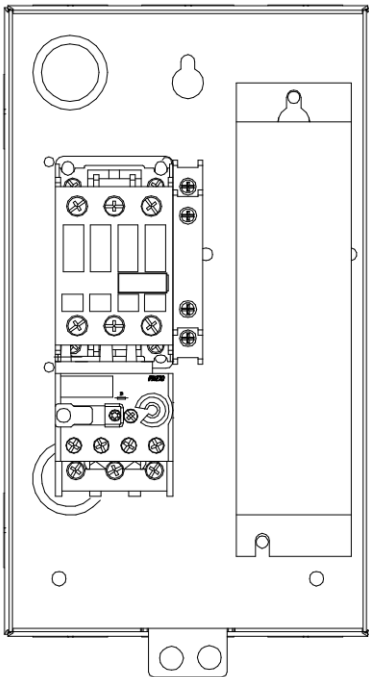

ELETRICAL SINGLE-PHASE DIAGRAM WITH STARTER SWITCH

<p>SUPPLY VOLTAGE 208-240V 60Hz FUSES UNDER CUSTOMER RESPONSIBILITY</p>	<p>SINGLE-PHASE MOTOR (STANDARD) DIRECT STARTER</p>	<p>ON/OFF</p>
--	--	----------------------

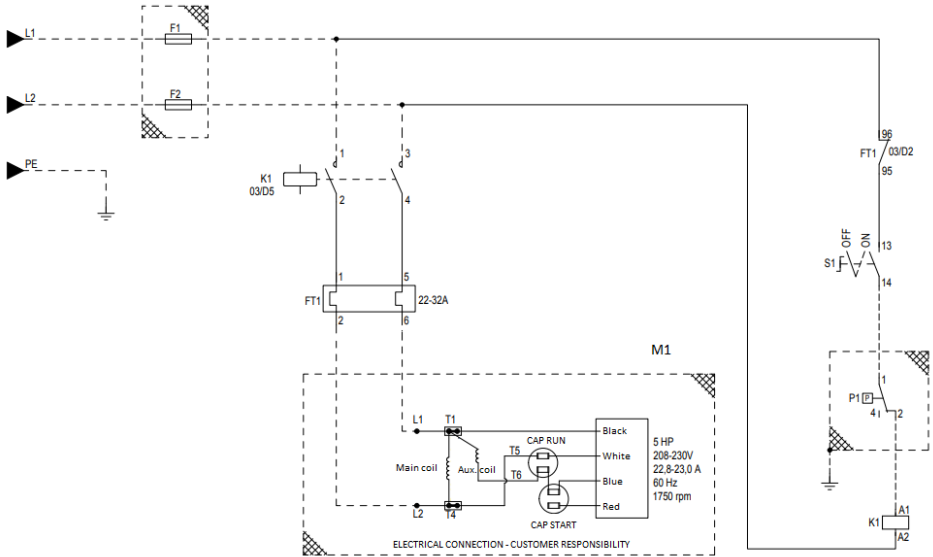

SUBTITLE	
TAG	DESCRIPTION
F1	FUSES
F2	
P1	PRESSURE SWITCH
K1	MAIN CONTACTOR
FT1	OVERLOAD RELAY
M1	ELETRIC MOTOR
S1	SWITCH ON/OFF

SINGLE-PHASE ELECTRICAL STARTER SWITCH

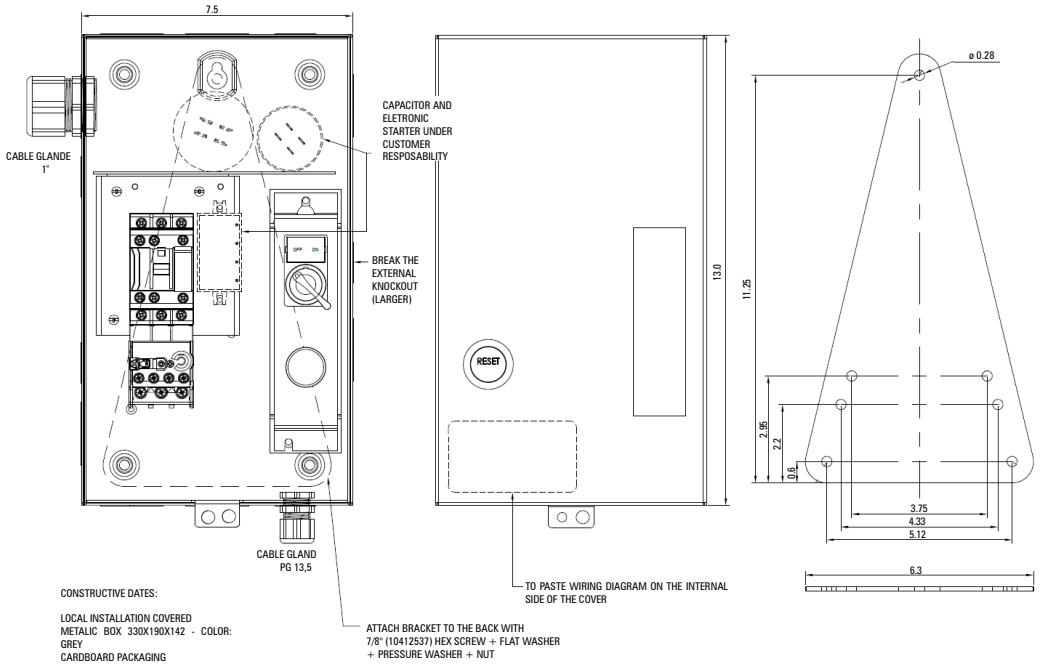

27. TECHNICAL DATA MCSV-20 HEAVY DUTY

MODEL	DISPLACEMENT		MAXIMUM PRESSURE		AIR RECEIVER TANK		Flow	ELECTRIC MOTOR				DIMENSIONS (INCH/M.M)					AIR DISCHARGE CONNECTION	OIL CAP		WEIGHT		COLOR REF.
	cfm	l/min	psig	bar	Geom. Volume			rpm	hp	KW	Hz	Polcs	Voltage (V)	A	B	C		D	E	ml	lbs	
MCSV-20 AP AUDAZ Three-phase	20	566.4	175	12	76	20	1710	5	3.7	60	4	230	35.8/910	10.6/270	38.2/970	20.1/510	14.6/370	1/2"	1200	320	145	Black (Pump) Gray (Tank)

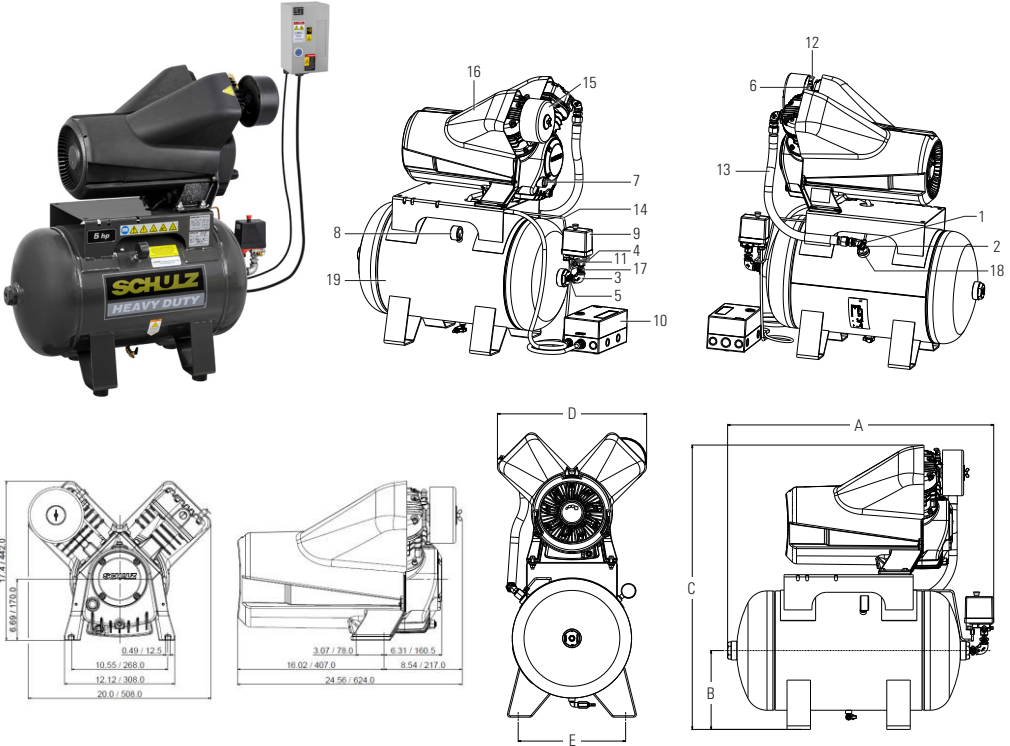

N°	CODE	DENOMINATION	QTY.	N°	CODE	DENOMINATION	QTY.
1	003.0054-3/AT	1/8"NPT Male stud fitting for pipe D=1/4"	1	11	022.0162-0/AT	1/4" ASME safety valve	1
2	003.0150-7/AT	1/2" BSP 90° male x female elbow	2	12	022.0215-0/AT	1/8" ASME safety valve	2
3	003.0163-9/AT	1/2" BSP 90° female x female elbow	1	13	028.0979-0/AT	Flexible hose with fittings	1
4	003.0180-9/AT	1/4 plug	2	14	709.2294-0/AT	Pressure Relief Tube	1
5	003.0194-9/AT	1/2" BSP NIPLE	1	15	809.2416-0	Air filter (3/4 NPT Coupling thread)	1
6	003.0208-2/AT	1/8 NPT brass male x female elbow	1	15.1	830.1257-0	Air filter element	1
7	830.0775-0/AT	3/4" oil level sight	1	16	932.7559-0	Barepump CMSV 20 AP 230V (Threphase)	1
8	830.1673-0	Pressure gauge	1	17	55015053	1/2 BSP x 1/4 POL BSP NIPLE	1
9	012.1606-0/AT	Pressure switch	1	18	60281012/AT	Check valve	1
10	012.2730-0/AT	Three Phase electrical starter with cables	1	19	25004182U/CZ/A	20GAL horizontal tank	1

BARE PUMP PARTS

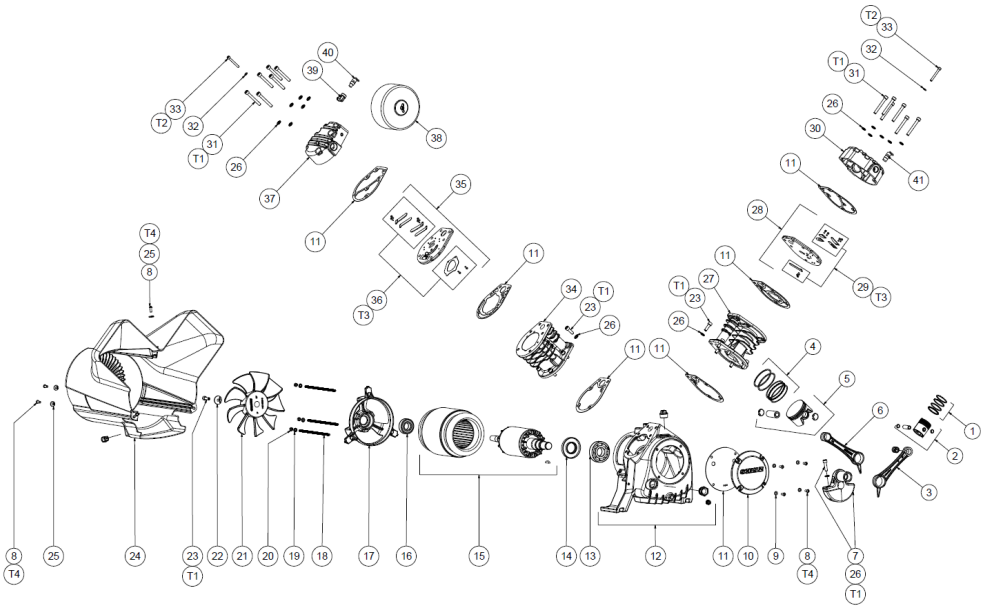

SCREW LIST - Applying torque values				
Number	TORK		DENOMINATION	
	-	N.m		
23	T1	33	288,8	M8- 1,25 x 25 mm
31	T1			M8- 1,25 x 65 mm
7	T1			M8- 1,25 x 30 mm
33	T2	12	105	M6- 1 x 50 mm
29/36	T2	2,2	19,25	M3- 0,5 x 8 mm
8	T2	12	105	M6- 1 x 16 mm

N°	CODE	DENOMINATION	QTY.
1	830.1268-0	Piston Ring Set (High Pressure)	1
2	701.0416-0/AT	Piston (High Pressure)	1
3	830.1269-0	Connecting rod (High Pressure)	1
		Needle bearing	1
4	830.1229-0/AT	Piston Ring Set (Low Pressure)	1
5	016.0123-0/AT	Piston (Low Pressure)	1
6	709.2053-0/AT	Connecting rod (Low Pressure)	1
7	709.2065-0/AT	Crankshaft	1
		Socket Head Cap Screws M8 1,25 x 30mm, Class 12.9	1
		Lock washer Nd = 8 mm	1
8	*	Button Head Screw M6 1 x 16 mm, Class 12.9	7
9	*	Flat washer Nominal diameter = 6,5 mm x External diameter = 12 mm	1
10	830.2662-0	Front cover assembly	1
11	830.2621-0	Sealing assembly	1
12	830.2622-0	Crankcase	1
		Bushing	1
		Pressure Plug 1/4" BSP	1
		Pressure Plug 3/4" BSP	1
13	019.0111-0/AT	Bearing	1
14	023.0500-0/AT	Oil seal	1
15	015.1168-0/AT	Three Phase Electric motor 230V 60Hz	1
15.1	015.1194-0/AT	Single Phase Electric motor 230V 60Hz	1
16	019.0117-0/AT	Bearing	1

N°	CODE	DENOMINATION	QTY.
17	709.2064-0/AT	Electric motor cover	1
18	*	M6- 1 x 200 mm screw rod. (three phase) / M6- 1 x 220 mm screw rod. (Single phase)	3
19	*	Lock washer Nd = 6 mm	3
20	*	Hex nut M6 - 1	3
21	709.2066-0/AT	Propeller	1
22	*	Flat washer Nominal diameter = 8 mm x External diameter = 29 mm	1
23	*	Socket Head Cap Screws M8 1,25 x 25mm, Class 12.9	13
24	028.0776-0/AT	Protection cover (Three Phase)	1
		Cable gland	1
24.1	028.0942-0/AT	Protection cover (Single Phase)	1
		Electrical conduit	1
25	*	Flat washer Nominal diameter = 7 mm x External diameter = 17 mm	3
26	*	Lock washer Nd = 8 mm	25
27	709.2058-0/AT	Cylinder (High Pressure)	1
28	830.2669-0	Valve plate assembly (High Pressure)	1
29	830.2624-0	Valve plate repair (High Pressure)	1
30	709.2126-0/AT	Cylinder cover (High Pressure)	1
31	*	Hex head bolt M8 - 1,25 x 65 mm, Class 12.9	12
32	*	Copper flat washer , Nd = 6,5 mm x Ed = 11 mm	2
33	*	Socket Head Cap Screws M6 1 x 50mm, Class 12.9	2
34	709.2125-0/AT	Cylinder (Low Pressure)	1
35	830.2663-0	Valve plate (Low Pressure)	1
36	830.2626-0	Valve plate repair (Low Pressure)	1
37	709.2128-0/AT	Cylinder cover (Low Pressure)	1
38	809.2416-0	Air filter (3/4 NPT Coupling thread)	1
38.1	007-0118-0	Air filter element	1
39	*	Elbow 1/8 NPT (Male female)	1
40	022.0177-0	HP 1/8" ASME safety valve	1
41	022.0215-0	HP 1/4" ASME safety valve	1

*Part available in the market (not sold by Schulz).

Follow the guideline for proper installation of the product, the electrical installation is the responsibility of the user (owner).

1 - Remove the three fixing screws on the protective cover as shown bellow.

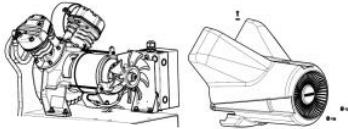

2- The motor must be grounded in accordance with national regulations to prevent electric shock. Make the electrical connection according to the electrical diagram on the next pages and connect the grounding cable as indicated in the point (A).

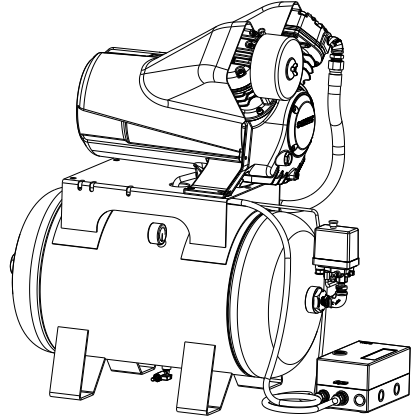

3- Check the fan direction, which should be clockwise as shown in the figure (B).

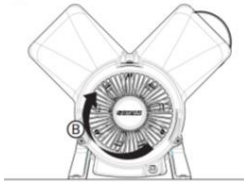

4 - For the motor connecting, feed the cable through the hole in the protection cover and use the cable gland to clamping it. (Figure C). Then connect the cable to the pressure switch according indicated in the point (D).

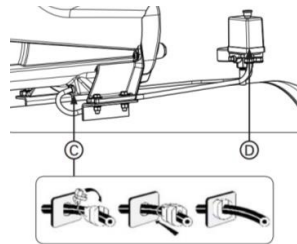

5 - Three phase electric motor connections.

1710 rpm	1 SF	230 V	
5 cv - hp	3 ~	16.5 A	
3,7 kW	60 Hz		
S3 70% Duty	1000 Alt. Max		

ELECTRICAL THREE PHASE DIAGRAM WITH STARTER SWITCH

<p>SUPPLY VOLTAGE 208 240V 60Hz FUSES UNDER CUSTOMER RESPONSIBILITY</p>	<p>SINGLE PHASE MOTOR (STANDARD) DIRECT STARTER</p>	<p>ON/OFF</p>
--	--	----------------------

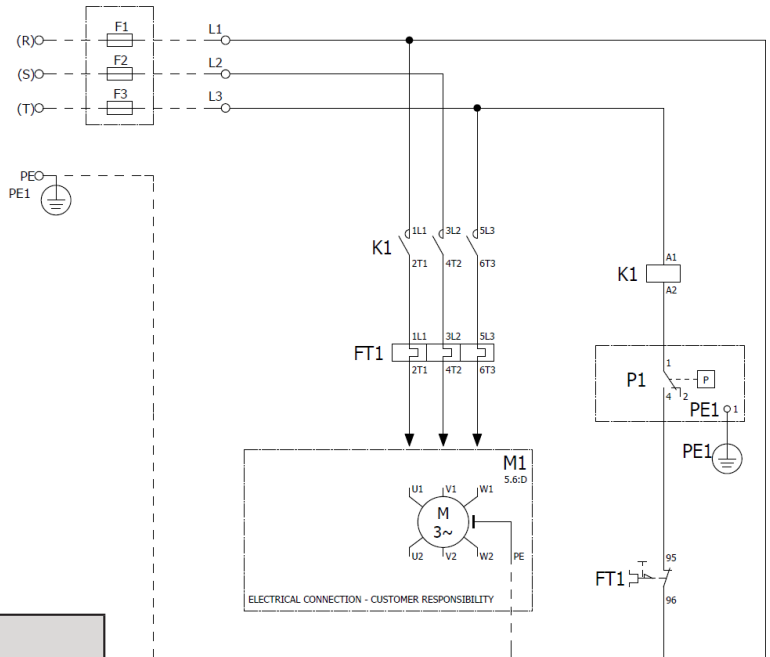

SUBTITLE	
COMPONENT	DESCRIPTION
	TREE-POLE CONTACTOR
	ELECTRIC MOTOR
	OVERLOAD RELAY
	SUPPLY FUSE
	PRESSURE SWITCH
	GROUND

THREE PHASE ELECTRICAL STARTER SWITCH

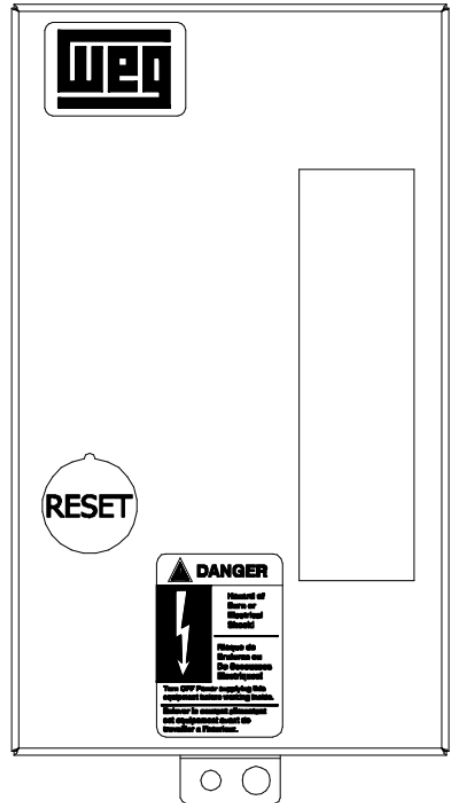
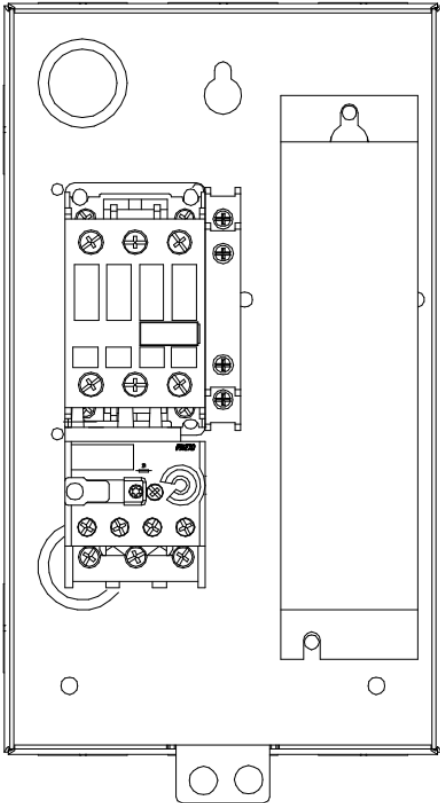

28. ENVIRONMENTAL GUIDANCE AND RECOMMENDATIONS

With the goal of extending environmental awareness and best practices to its customers, Schulz provides guidance related to proper disposal of different types of waste generated from the brand's products, aiming at reducing environmental impact.

Disposal of solid waste (parts and product packaging)

The creation of solid waste is one aspect that must be considered by the user in the use and the maintenance of the equipment. The impacts on the environment may cause significant changes in the quality of the soil, in surface and underground water, and in the population's health due to improper disposal of the discarded waste (on streets, water springs, landfills, etc.).

Schulz recommends that the waste resulting from the product, from its generation, use, transportation, and treatment to its final disposal shall be handled carefully.

Proper handling should consider the following stages: quantification, qualification, classification, reduction at source, pick-up and selective pick-up, recycling, storage, transportation, treatment and final destination.

Waste disposal should be done in compliance with the requirements of local legislation in effect.

Wastewater Disposal

The presence of wastewater or non-treated condensate from the tank or condensate separator in rivers, lakes or in other water receiving bodies may adversely affect the aquatic life and the water quality. Therefore, Schulz recommends treating wastewater properly, according to the provisions of local legislation in force. The condensate withdrawn daily from the tank or condensate separator, according to the chapter "Preventive Maintenance", must be kept in a container and/or in an appropriate collecting network for further treatment. Schulz sells Water and Oil Separators that can help to treat this type of waste.

Compressor unit lubricating oil, as well as its packaging

Disposal of lubricating oil, resulting from product oil change, must meet the requirements of current legislation.

29. SCHULZ AUTHORIZED DEALER

Find the nearest Schulz authorized dealer in our website: www.schulzamerica.com or call + 55 47 3451 8290 (from Monday to Friday, from 8 am to 6 pm).

Número de Série: _____

Data: ____/____/____

100%
RECYCLABLE
SCHULZ



ATENDIMENTO TÉCNICO BRASIL

0800 347 4141

de segunda a sexta-feira, das 8h às 18h

PEÇAS ORIGINAIS

Consulte a Rede de Assistência Técnica Autorizada



SCHULZ COMPRESSORES LTDA.

CNPJ: 23.635.798/0001-43
Rua Dona Francisca, 6901 A
Telefone: 47 3451.6000
89219-600 - Joinville - SC
sac@schulz.com.br
www.schulz.com.br



INFORMACIÓN TÉCNICA

TECHNICAL INFORMATION

export@schulz.com.br

+ 55 47 3451 8290

PIEZAS ORIGINALES

Consulte al Distribuidor Autorizado

ORIGINAL REPLACEMENT PARTS

Contact Authorized Distributor



SCHULZ OF AMERICA, INC.

3500, Lake City Industrial Court
Acworth, GA 30101
Phone # (770) 529.4731
Fax # (770) 529.4733
sales@schulzamerica.com
www.schulzamerica.com

RECYCLABLE RECYCLABLE RECYCLABLE

03/25

025.0513-0 rev.11